

**TEFC THREE PHASE
GEARMOTOR**

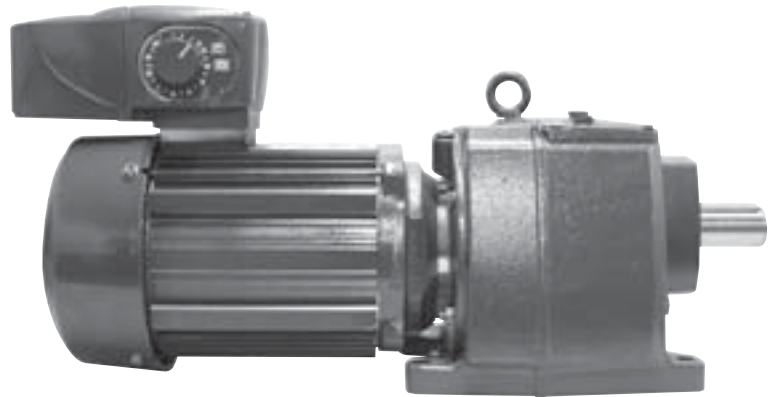

**INTELLIGEAR
GEARMOTOR**

Gearmotor Section..... Page 2 - 119

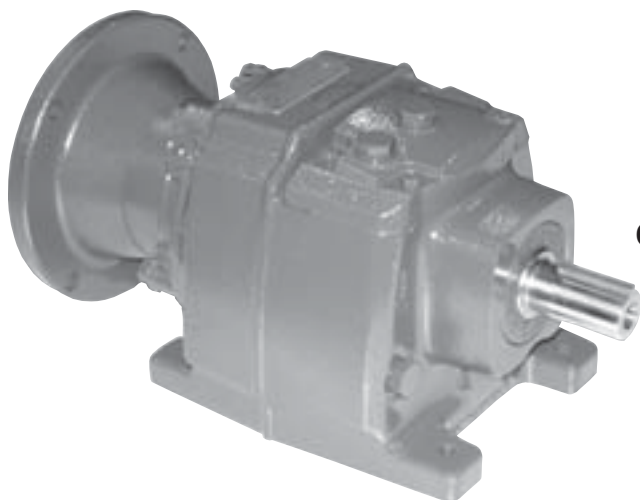

C-FACE REDUCER

Reducer Section..... Page 121 - 178

Electrical Technical Data Page 177 - 185



TYPE CbN INLINE HELICAL SERIES 3000 GEARMOTORS FEATURES...

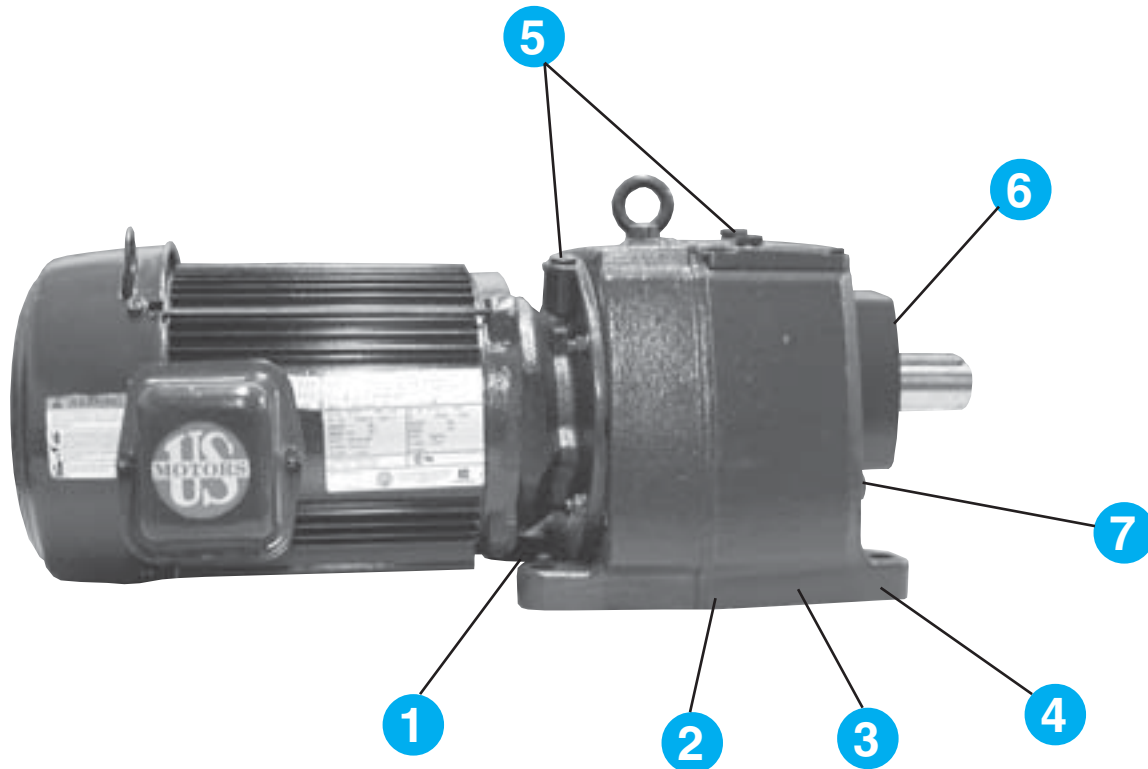

Design Features

1. Innovative self-locking taper shaft connection (motor to gear) allows on-site replacement without removing oil, primary pinion, or disconnecting the load. This provides precision alignment and eliminates fretting to expedite motor removal.
2. Gearbox is delivered filled with synthetic oil, ready to use.
3. Corrosion resistant cast iron housings are one piece and ribbed for extra strength. (Size 30 is cast aluminum housings.)
4. Gears are made of 8620 heat treated nickel chromium molybdenum steel. Helical gearing is skived, superfinished, or ground after case hardening to 58-62 Rc.
5. Multiple breather locations. Breathers are normally closed construction to exclude contaminants.
6. Double lip seals are installed on plunge ground shafts.
7. Magnetic drain plug is supplied as standard.



Table of Contents

Section	Page
Mounting Versatility and Size Range	4 & 6
General Information	5
Motor Options	7
Gearmotor Selection (constant speed)	8-9
Gearmotor Selection (variable speed)	10-11
Catalog Nomenclature	12-13
Mounting Positions	14-15
Electrical Connection Options	16
Lubrication	17-18
Modifications, Options and Accessories	19-21
AGMA Application Classifications	22-24
Gearmotor Selection Tables	25-48
Dimension Prints (inch)	
Three Phase Footed	49-62
Three Phase Flange Mounted	63-77
INTELLIGEAR™ Footed	78-87
INTELLIGEAR™ Flange Mounted	88-96
Single Phase Footed	97-106
Single Phase Flange Mounted	107-118
Gearmotor Weights	119
Dimension Print Supplements	
Face Mounted	172-173
Metric Output Shafts	174-177
Reducer Weights	178
Gearmotor - Typical Motor Performance Data	179-182
INTELLIGEAR™ Technical Specifications	183-187
General Information	188-189
Standard Terms and Conditions of Sale	192



GEARMOTORS

CbN SERIES 3000

Mounting Versatility and Size Range

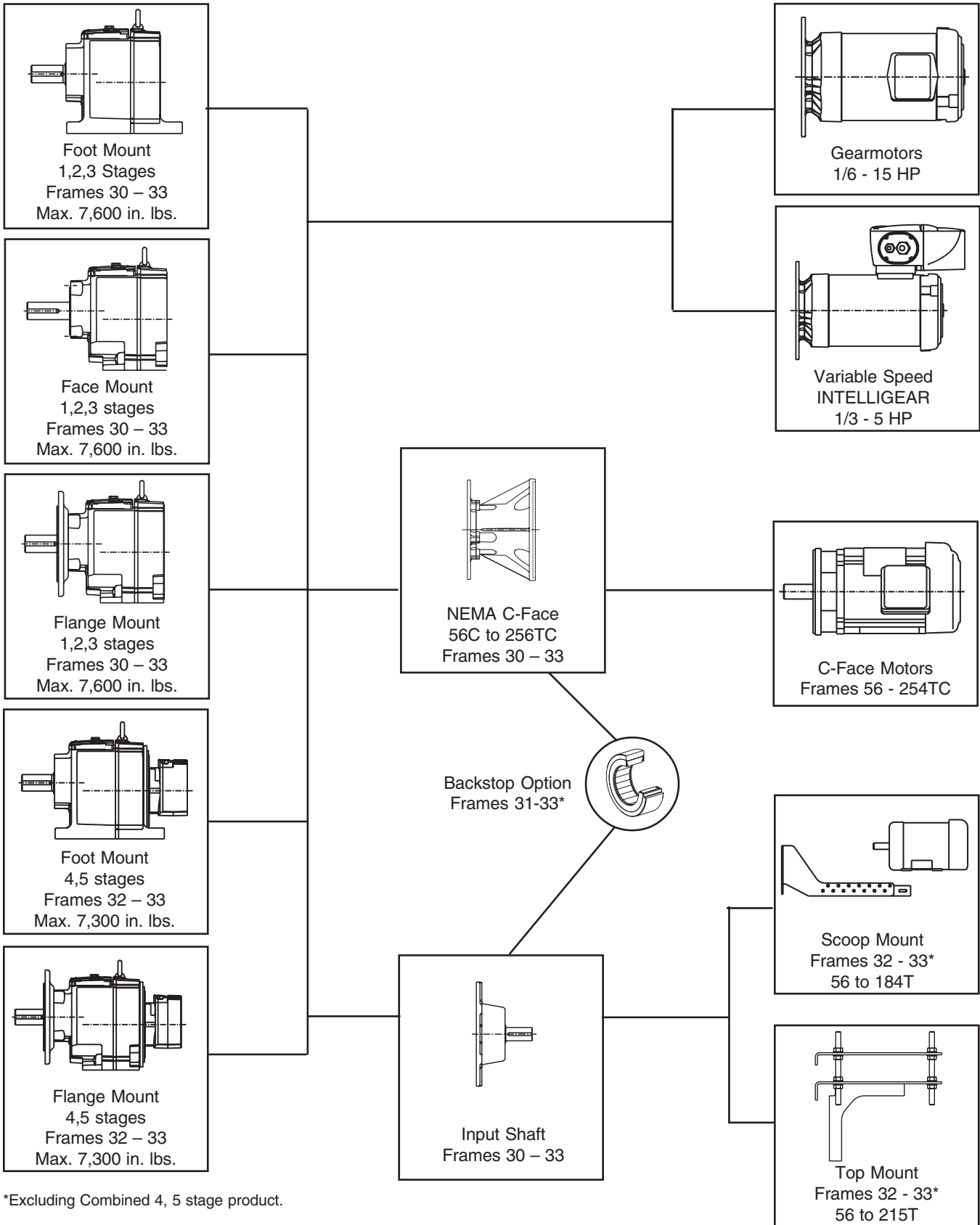

*Excluding Combined 4, 5 stage product.



SELECTION INFORMATION

GENERAL

CbN Series 3000 helical gearmotors and speed reducers incorporate the latest in design and manufacturing technologies to deliver an energy efficient helical gear train combined with either a constant or variable speed motor. This latest generation of CbN in-line gearing is 98% efficient per gear stage, and boasts total efficiency improvements over previous designs by delivering up to 50% more total speed reduction without added gear stages.

HOUSING

One piece housings replace the classical two piece designs to improve alignment and overhung load integrity in the most demanding applications. Extremely compact envelopes provide low profiles and the footprint to directly interchange with older CbN product for simple aftermarket replacements. All housings are cast, with frames 31 to 33 made with high strength cast iron. Motor interfaces are generally shorter than previous CbN designs.

PERFORMANCE

Series 3000 product delivers up to 35% more capacity than previous CbN product in equivalent frames. For replacements, this means longer life. For new applications, this means cost savings through possible downsizing. Each CbN unit is factory filled with synthetic lubricant, ready to operate in a wide band of ambient temperatures with minimal in-service maintenance.

FLEXIBILITY

Improvements in Series 3000 designs begin with the expansion of flange mounting options available. Three phase motor designs now incorporate an upgraded wire and varnish treatment called ALLGUARD making many of them suitable for inverter applications. C-Face inputs utilize a compact quill design with a non-metallic liner and metal key to eliminate fretting corrosion while delivering a compact length. Each 31 to 33 housing can be oriented in different mounting positions by a minor adjustment in oil volume and relocation of breather/drain locations. VARIDYNE inverter duty motor designs deliver up to 10:1 constant torque speed range gearmotors off the shelf.

GEARMOTORS

A diverse array of different motor constructions and voltages in three and single phase are stocked to meet most industry and USER specifications. This now includes INTELLIGEAR variable speed TEFC gearmotors incorporating a rugged, compact, pre-programmed AC controller onboard for simple 6:1 constant torque speed ranges.

RELIABILITY

Gear housings 31 to 33 are fitted with normally closed breathers, excluding outside contaminants and preserving low internal operating pressure. All oil seals operate on plunge ground shaft surfaces to deliver extended life. Enhanced insulating materials and other standard features of our VARIDYNE Inverter duty motors carry a 3 year warranty when operating with PWM inverter power up to 575 VAC.

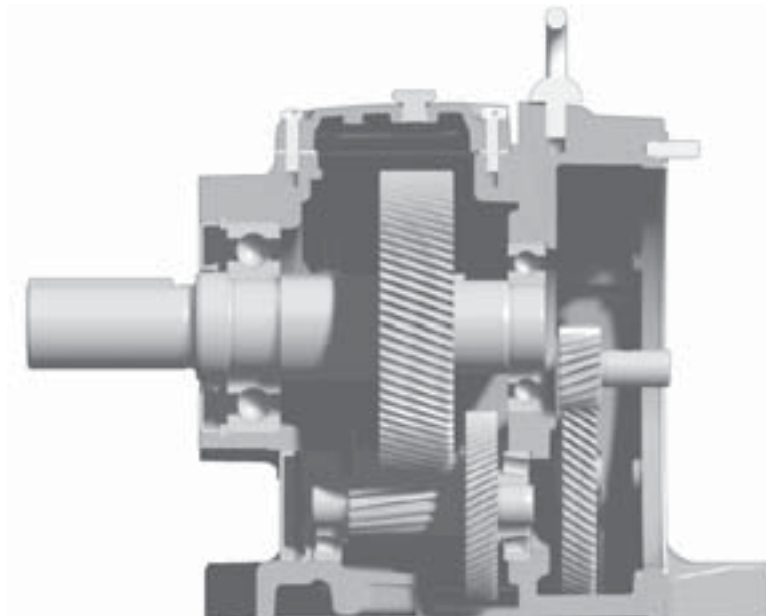



GEARMOTORS

CbN SERIES 3000

Mounting Versatility and Size Range

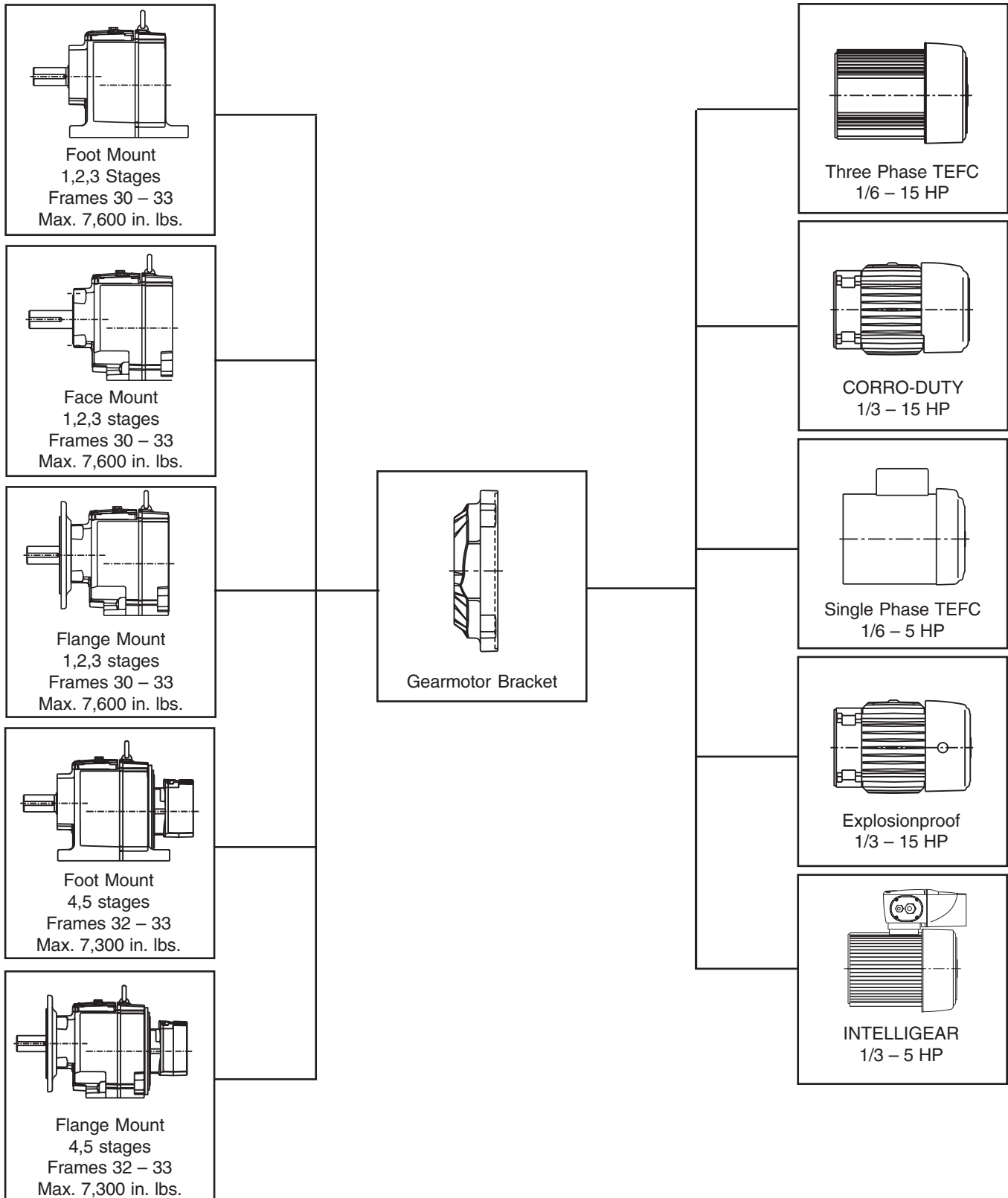



Motor Options

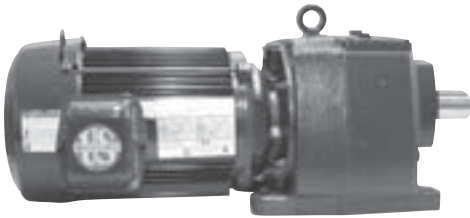

TEFC – THREE PHASE

- Suitable for general purpose industrial applications
- Energy efficiency design standard
- 1.25 service factor through 30 HP; 1.15 service factor above 30 HP
- Suitable for 50 Hz, 190/380 VAC through 30 HP
- Premium class F Allguard insulation standard
- 40°C ambient, NEMA B design, continuous duty
- Premium efficiency available
- Inverter duty option per NEMA Part 31 stocked

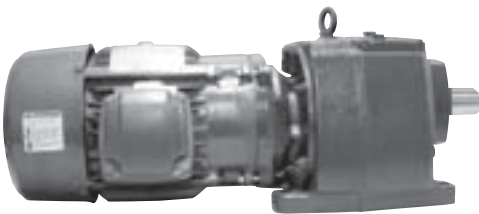

CORRO-DUTY

- Designed for washdown applications and industries including waste treatment, mining and lumber.
- All cast iron construction (56 and 140 frames are rolled steel)
- Premium efficiency standard 3 HP and above
- 1.15 service factor, class F Allguard insulation
- Condensation drains in motor and conduit box
- 40°C ambient, NEMA design B, continuous duty
- Inverter duty option per NEMA Part 31 stocked

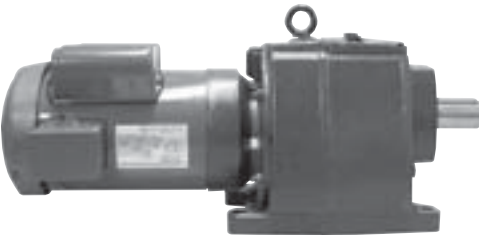

TEFC – SINGLE PHASE

- For agricultural, light material handling, textile, and light pumping applications
- 1.25 service factor
(1.15 service factor, 1 HP, 48 frame)
(1.0 service factor, 2 through 5 HP)
- Capacitor start
(capacitor run above 1/2 HP, 48 frame)
(capacitor run above 1 HP, 56 – 140 frames)
- Class B insulation, continuous duty, reversible

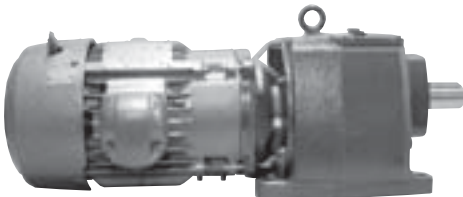

EXPLOSION PROOF

- Ideal for the petro-chemical, grain, mining, and chemical industries
- Class I, group D, class II, groups F and G
- All cast iron construction (plastic fan cover)
- 1.0 service factor, class B insulation
- 40°C ambient, NEMA B design, continuous duty
- UL approved Inverter duty per NEMA Part 31 stocked

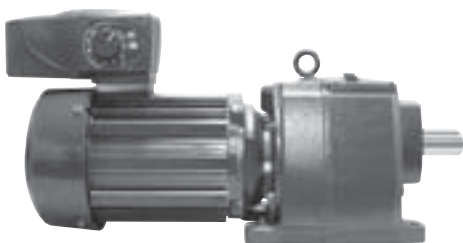

INTELLIGEAR

- Variable speed gearmotor with NEMA 3R/12 enclosure
- "Onboard" pushbutton and remote speed changing options
- Pre-programmed 6:1 Constant Torque speed range
- Versions for 3/460V input power supplies from 1/3 to 5 HP
- 1/230V and 3/230V through 2 HP
- UL, CUL and CE



CONSTANT SPEED Gearmotor Selection

CbN
SERIES 3000

SELECTION INFORMATION

- Input HP
 - Based on application data.
- Speed / Ratio
 - Obtain either desired output speed (RPM) or gearbox ratio based on application.
- Mechanical Service Factors - Gears
 - There are three standard classifications for gearmotor applications:

CLASS I - Uniform loading, 3-10 hours per day, service factor 1.0 (minimum).

CLASS II - Uniform loading over 10 hours per day or moderate shock loading up to 10 hours per day; service factor 1.4 (minimum).

CLASS III - Moderate shock loading over 10 hours per day or heavy shock loading up to 10 hours per day; service factor 2.0 (minimum).

- The tables on pages 22 through 24 are based on past operating experience within the industries listed and information gathered by AGMA. If the user has data reflecting greater severity than normal industry usage, then AGMA class should be increased.
- Choose the AGMA class for your given application based on this criteria. If your application cannot be found, use the following table to determine service factor.

Duty Cycle	Hours Operation	Uniform Load U	Moderate Shock Load M	Heavy Shock Load V
CONTINUOUS	0 - 3	0.80	1.00	1.50
	3 - 10	1.00	1.25	1.75
	10 - 24	1.25	1.50	2.00
FREQUENT STARTS/STOPS*	0 - 3	1.00	1.25	1.75
	3 - 10	1.25	1.50	2.00
	10 - 24	1.50	1.75	2.25

*Greater than 10 per hour

SIZE SELECTION

Step 1 - Locate gearmotor selection tables (pages 25 - 48) based on input HP.

Step 2 - Choose the appropriate nominal speed required.

Step 3 - Select the correct gearmotor based on AGMA class or service factor determined in selection information.

Step 4 - Verify overhung load ratings where required (see below).

OVERHUNG LOAD

When a sprocket, sheave, pulley, or pinion is mounted on the take-off shaft of a gearmotor, it is necessary to calculate the overhung load. This calculated load must be compared with the gearbox capacity listed to make sure the gearbox will not be overloaded. To calculate the overhung load you need to know the torque or horsepower at the take-off shaft and the location along the shaft at which the load is applied.

A. If torque is known:

$$OHL = \frac{T \times K \times LLF}{r}$$

B. If horsepower is known:

$$OHL = \frac{63025 \times HP \times K \times LLF}{RPM \times r}$$

Where:

- OHL = Overhung load (pounds)
- T = Torque (in. lbs.)
- r = Radius of driving member (in.)
- HP = Horsepower
- K = Drive type factor
- LLF = Load location factor

DRIVING MEMBER	VALUE OF K
Chain Drive	1.00
Pinion	1.25
V-Belt	1.50
Timing Belts	1.25

LOAD LOCATION	VALUE OF LLF
End of shaft extension	1.20
Center of shaft extension	1.00
Shaft extension shoulder	0.80



CONSTANT SPEED Gearmotor Selection

CbN SERIES 3000

EXAMPLE

A horizontal, foot mounted gearmotor is required to operate a uniformly loaded assembly conveyor at 44 RPM, 24 hours per day. An 8" diameter sprocket is mounted at the end of the shaft and drives the conveyor with a chain. The load is 3 HP and customer requests a standard 230/460 volt TEFC motor end and normally closed breather in gear case.

Step 1...

AGMA service classification table on page 22 indicate that this is a CLASS II application.

Step 2...

Page 42 CbN gearmotor table indicates that a gear frame 3363 will do the job.

Output RPM	AGMA Class	Service Factor	Output Torque in-lb	OHL Δ lb	Nominal Ratio	Frame Size Gear	Motor	Std. Motor Types ◇
44	I,II	1.4	4099	2305	40	3363	182T	T,S,C,X, IG

Step 3...

To check overhung load for the example:

$$r = \frac{\text{Sprocket Diameter}}{2} = \frac{8}{2} = 4$$

$$K = 1.0 \text{ (chain drive)}$$

$$LLF = 1.2 \text{ (sprocket on end of shaft)}$$

$$HP = 3$$

Torque formula:

$$OHL = \frac{63025 \times HP \times K \times LLF}{RPM \times r}$$

$$OHL = \frac{63025 \times 3 \times 1.0 \times 1.2}{44 \times 4} = 1289 \text{ lbs.}$$

Overhung load capacity of 2305 lbs. listed is greater than the calculated overhung load value of 1289 lbs.

Step 4...

Check modification M12 from page 21 for normally closed breather. Series 3000 comes standard with this breather design.

Step 5...

Catalog designation (see "Ordering" page 13):

CbN • 3363 • S • B3 • 40 • MT • 182T • 3



VARIABLE SPEED Gearmotor Selection

CbN
SERIES 3000

SELECTION INFORMATION

1. Determine Installation Environment
 - Control enclosure is NEMA 12/3R
2. Input HP
 - For constant torque loads this is at maximum speed of range
3. Speed Range
 - Confirm maximum and minimum of 6:1 range.
4. Determine Control Power Supply
 - Phase and voltage.

Power Supply	Input HP's
1 ph / 230 v	.33 to 2
3 ph / 230 v	.33 to 2
3 ph / 460 v	.33 to 5
3 ph / special	R. O.

5. Mechanical Service Factoring of Gear
 - Refer to Page 8 for this procedure.

Note: INTELLIGEAR application for 1 phase power supply is limited to 10 starts per hour.
6. Determine Speed Adjustment Option
 - Select from:
 - P1 = Run/Stop/Speed Pot. mounted on INTELLIGEAR enclosure
 - P2 = Forward/Reverse/Stop/Pot. mounted on INTELLIGEAR enclosure
 - P3 = Speed Pot. (only) mounted on INTELLIGEAR enclosure (start/stop by others)
 - P4 = Speed Pot. (only) mounted inside INTELLIGEAR enclosure (start/stop by others)
 - R = Remote Signal Following (0-10VDC or 4-20mA supplied by others)
 - RP = Remote From Fieldbus - Profibus DP
 - RI = Remote From Fieldbus - INTERBUS S
 - RD = Remote From Fieldbus - DEVICENET
 - RC = Remote From Fieldbus - CAN OPEN

SIZE SELECTION

- Step 1 - Locate gearmotor selection tables based on the input HP required at maximum speed of the range.
- Step 2 - Select the "Output RPM" closest to the maximum speed of the range desired. If the motor HP is 5, make the RPM selection using the following formula:

$$\text{"Output RPM" Selection} * = \frac{\text{Max. Speed of Range}}{1.2}$$
- Step 3 - Note the gear ratio after step 2.
- Step 4 - Select correct gearmotor that meets or exceeds the AGMA class or service factor determined in the selection information.
- Step 5 - Verify overhung load rating where applicable per formulas on Page 8.
- Step 6 - Confirm input power supply is compatible with HP of selection and record speed adjustment option desired for the applicaiton.
- Step 7 - Referring to Page 16, determine if an alternate controller location is required for the application. Default location is "FO" (at 12 O'Clock).

* Maximum motor RPM will be 2150 @ 74 Hz for 5HP INTELLIGEAR.



INTELLIGEAR

Gearmotor Selection

CbN
SERIES 3000

SELECTION EXAMPLE

A foot mounted gearmotor is required to operate a positive displacement pump from 220 to 40 RPM, 16 hours a day in a waste treatment plant. The output shaft will be coupled to the pump. The customer required 4.5 HP at the maximum RPM. The jobsite power supply is 3 phase and 460 VAC. The control of speed requires the INTELLIGEAR to follow a 4-20 mA signal supplied by a process control system.

Step 1...

The closest gearmotor HP to meet this application is a 5 HP design.

Step 2...

Determine the specific selection output RPM and ratio for 5 HP INTELLIGEAR

$$\text{Maximum Speed} / 1.2 = \text{"Selection Table" RPM}$$

$$220 / 1.2 = \text{approx. 183 RPM}$$

Step 3...

AGMA service classification indicates this is an AGMA CLASS II application. From this information, on Page 44 a CbN 3252 and motor frame 184T with 10:1 nominal ratio is the correct gearmotor.

Output RPM	AGMA Class	Service Factor	Output Torque in-lb	OHL Δ lb	Nominal Ratio	Frame Size Gear	Motor	Std. Motor Types ◊
181	II	1.8	1663	818	10	3252	184T	T,S,C,X,IG

Step 4...

This application does not involve any OHL calculations due to coupling connection.

Step 5...

The power supply of 3 phase / 460 VAC is ok for 5 HP INTELLIGEAR and the speed changing option will be "R" per table on preceding page.

Step 6...

Catalog designation (see also "Ordering" on page 13) will be

CbN • 3252 • S • B3 • 10 • T4 • 184T • 5 w/"R" speed option



GEARMOTOR

Catalog Nomenclature

CbN
SERIES 3000

CbN • 3012 • S • B3 • 40 • MT • 145T • 1.5

Based on Selection

Choose one

Choose one

Based on Application

Type	Series & Gear Frame	Number of Reductions	Mounting Configuration	Mounting Plane	Gear Ratio	Motor Input	Motor Frame	Motor HP
CbN	30	1 = 1 stage	S =	Foot Mount (NEMA)	See Pages 14-15	Nominal Ratio Per Selection Pages	48	1/6
	31	2 = 2 stages					56	1/4
	32	3 = 3 stages	B14 =	Face Mount (NEMA)			143T	1/3
	33	4 = 4 stages					145T	1/2
		5 = 5 stages	BS =	Flange Mount (NEMA)			145TY	3/4
							182T	1
			56C =	NEMA 56C Flange **			184T	1 1/2
			BD1,2, or 3 =	Flange ** Mount (NEMA)			213T	2
			SM =	Foot Mount (Metric)			215T	2 1/2
			BSM =	Flange Mount (Metric)			254T	3
		BDM1,2, or 3 =	Flange Mount (Metric)	256T	5			
					7 1/2			
					10			
					15			

** See Table Below for Availability and Alternatives

Gear Frame	Number of Reductions	Mounting Configurations				
		BS	BD			56C
			BDM1	BDM2	BDM3	
30	Any	Yes	Yes	Yes	Yes	Yes
31	Single	Yes	No	Yes	No	No
	Multiple	Yes	Yes	Yes	Yes	No
32	Single	Yes	No	Yes	No	No
	Multiple	Yes	Yes	Yes	No	No
33	Single	Yes	No	Yes	No	No
	Multiple	Yes	Yes	Yes	No	No



Ordering

STANDARD MOTOR INPUT TYPES					
Motor Type	Speed - Design	Catalog Designation	Motor Description (not required)		
			Frame(s)	Voltage	Poles
S (Single Phase TEFC)	Single	MR	48 - 145TY	115/230	4
		MR2	184T	230	4
T (Three Phase TEFC)	Single Standard Efficiency	MT	48 - 256T	208-230/460	4
		MV	48 - 256T	575	4
		MO	56 - 256T	230/460	6
		MW	56 - 256T	575	6
	Single Premium Efficiency	MY	143T - 256T	230/460	4
		MZ	143T - 256T	575	4
	Inverter Duty	MI	56 - 256T	230/460	4
		MD	56 - 256T	575	4
	Two Speed (Constant Torque)	U2	56 - 256T	230	4/8 - 1 Winding
		U4	56 - 256T	460	4/8 - 1 Winding
U5		56 - 256T	575	4/8 - 1 Winding	
Single	Z1	56 - 256T	Special	4	
	Z2	56 - 256T	Special	6	
C CORRO-DUTY Three Phase	Single Standard Efficiency	MC	56 - 145TY	230/460	4
		MG	56 - 145TY	575	4
		MF	56 - 256T	230/460	6
	Single High Efficiency	MC	143T - 256T	230/460	4
		MG	143T - 256T	575	4
	Two Speed (Constant Torque)	C2	56 - 256T	230	4/8 - 1 Winding
		C4	56 - 256T	460	4/8 - 1 Winding
		C5	56 - 256T	575	4/8 - 1 Winding
Inverter Duty	C1	56 - 256T	230/460	4	
	CD	56 - 256T	575	4	
X Explosionproof	Single	MX	56 - 256T	230/460	4
		ME	56 - 256T	575	4
		Z7	56 - 256T	230/460	6
	Two Speed (Constant Torque)	X2	56 - 256T	230	4/8 - 1 Winding
		X4	56 - 256T	460	4/8 - 1 Winding
		X5	56 - 256T	575	4/8 - 1 Winding
	Inverter Duty	X1	56 - 256T	230/460	4
		XD	56 - 256T	575	4
	IG INTELLIGEAR TEFC/NEMA 3R+12 (motor/controller)	6:1 Range (Constant Torque) Variable Speed	TS2	56 - 145TY	1/230 *
T2			56 - 145TY	3/230 *	4
T4			56 - 184T	3/460 *	4

* Contoller input power. Controller output is 3 phase.

FOOT MOUNT S

SINGLE REDUCTION

B3

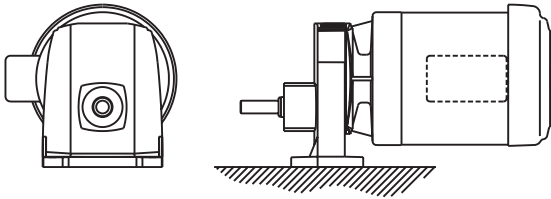

B8

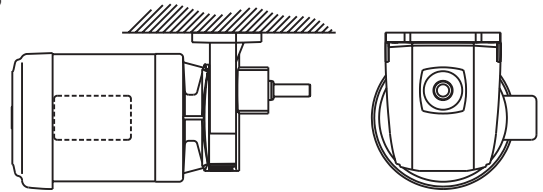

B6

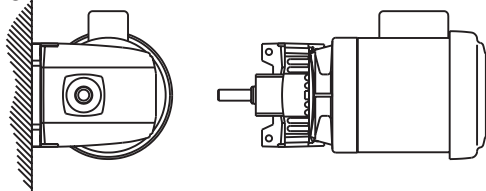

B7

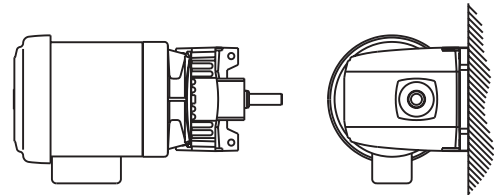

V5

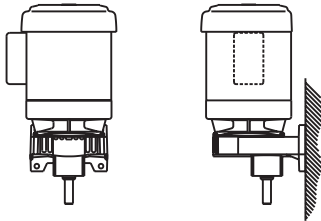

V6

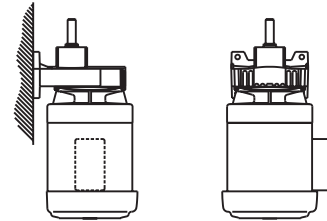

MULTIPLE REDUCTION

B3

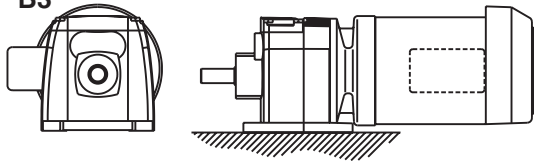

B8

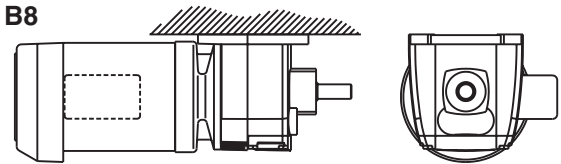

B6

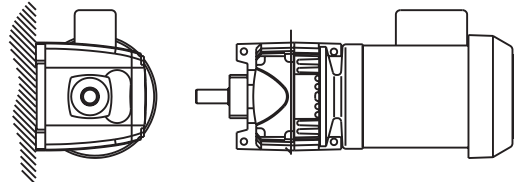

B7

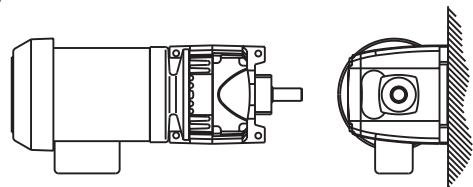

V5

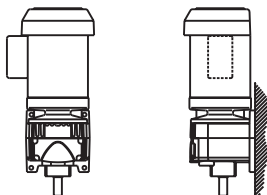

V6

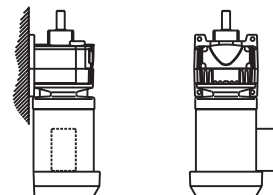

FACE AND FLANGE MOUNT BS, BD and BR

SINGLE REDUCTION

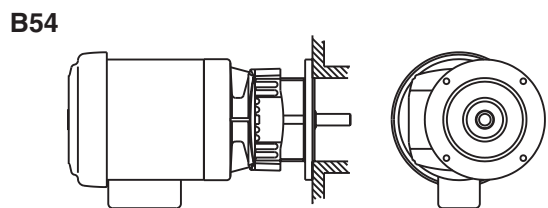
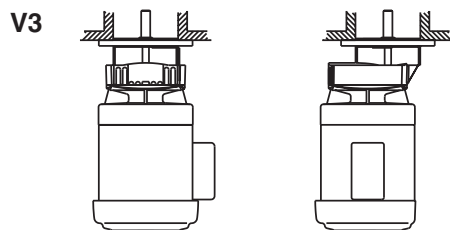
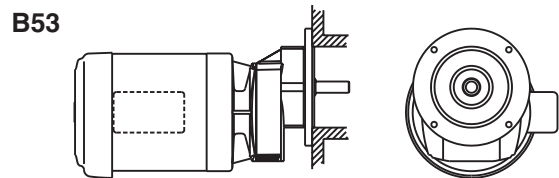
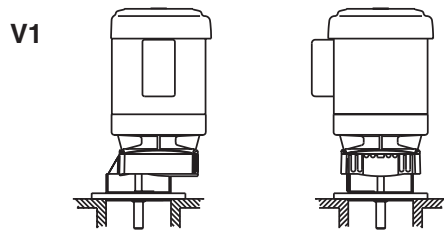
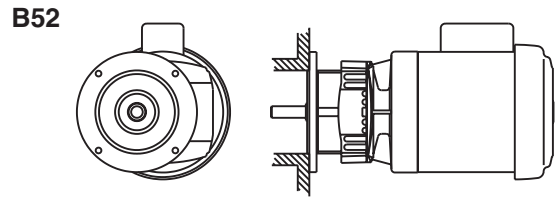
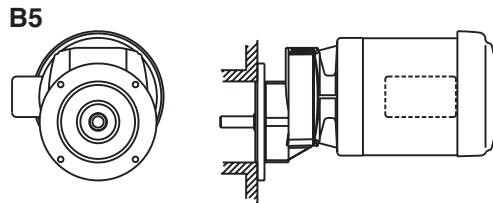

MULTIPLE REDUCTION

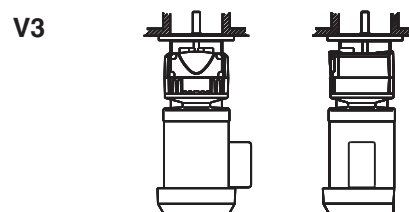
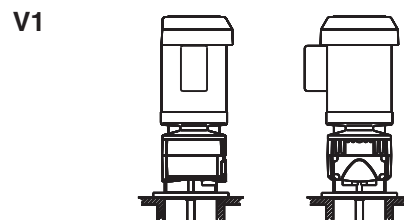
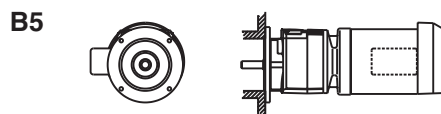



Electrical Connection Options

Conduit Box Location

When ordering a conventional CbN 3000 gearmotor, specify the desired conduit box location when viewing unit output shaft in B3 or B5 position. If no option is specified, the "F1" location will be supplied.

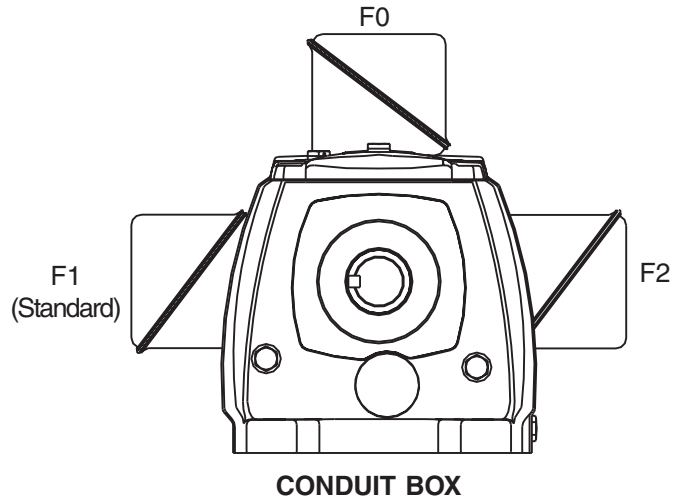

Controller Location

When ordering an INTELLIGEAR Series 3000 gearmotor, you can specify the controller location and conduit entry location when viewing the unit output shaft in B3 or B5 position. If no options are specified, the "F0" controller location will be supplied.

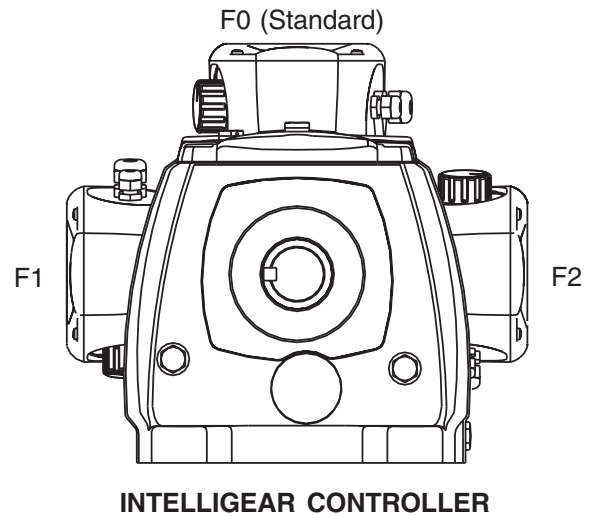

Cable Entry

INTELLIGEAR Cable Entry can be from either side of enclosure. If no option is specified, "A" will be supplied.

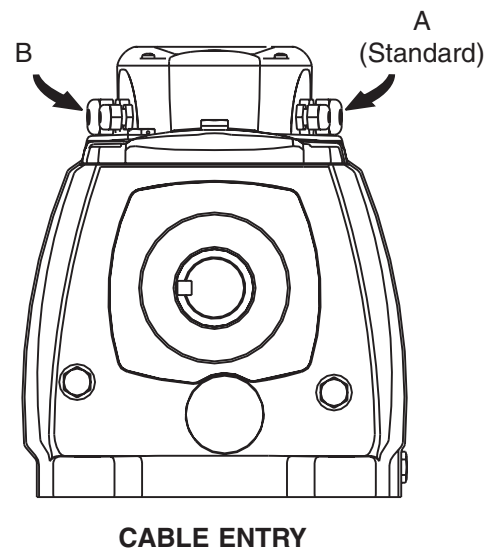



GEARMOTORS

Lubrication

CbN
SERIES 3000

Series 3000 CbN gearing is shipped with one of the following synthetic lubricants per the table below and fitted with a magnetic drain. Each reducer is filled according to the mounting position specified when ordered. Refer to unit nameplate and charts on pages 14-15 for mounting position arrangement of your unit.

In the case of synthetic oil, the lubricant does not require changing but it is recommended that the oil level be checked periodically.

SYNTHETIC

NO BACKSTOP

Manufacturer	-25° F to 125° F (-30° C to 50° C)
COFRAN	SINTOGEAR 125
MOBIL	SHC 629
SHELL	OMALA HD 150



- Never mix synthetic oil and mineral oil.
- Never use extreme pressure (EP) oil in a reducer with a backstop.

ACCEPTABLE MINERAL OIL LUBRICANTS

Manufacturer	-4° to 14° F (-20° C to 10° C)	14° to 122° F (-10° C to 50° C)				122° F and Above (50° C +)	
		NO BACKSTOP					WITH BACKSTOP
		ISO VG 68	ISO VG 100	ISO VG 150	ISO VG 220		ISO VG 150
COFRAN	Mecanep 68 GL	Cofraline Equitex 100	Mecanep 150	Equilux C2000 Super	Cofrapoid 80W 90	Mecanep 320	
MOBIL	Mobil Gear 626	Mobil Gear 627	Mobil Gear 629	Mobil Gear 630	DTE Extra Heavy	Mobil Gear 632	
SHELL	Omala 68	Omala 100	Omala 150	Omala 220	Morlina 150	Omala 320	

OIL CAPACITIES (U.S. QUARTS)

Reduction Stages	Gear Frame	Mounting Positions											
		B3	B5	B6	B7	B8	B52	B53	B54	V1	V3	V5	V6
One	30	Refer to Illustration below											
	31	0.34	0.34	0.5	0.5	0.71	0.5	0.71	0.5	0.52	1.06	0.52	1.06
	32	0.24	0.24	0.61	0.61	1	0.61	1	0.61	0.64	1.22	0.64	1.22
	33	1.16	1.16	2.01	2.01	2.64	2.01	2.64	2.01	2.01	1.69	2.01	1.69
Two & Three	30	Refer to Illustration below											
	31	0.6	0.6	1.3	0.87	1.2	1.3	1.2	0.87	1.23	1.65	1.2	1.65
	32	0.95	0.95	2.4	1.6	2.3	2.4	2.3	1.6	2.4	2.65	2.4	2.65
	33	1.5	1.5	4.6	2.9	5	4.6	5	2.9	4.7	4.4	4.7	4.4

The Company names and the names of the Lubricants mentioned in the above tables are the tradenames, trademarks and logotypes of the respective companies, and are not owned by EPT.

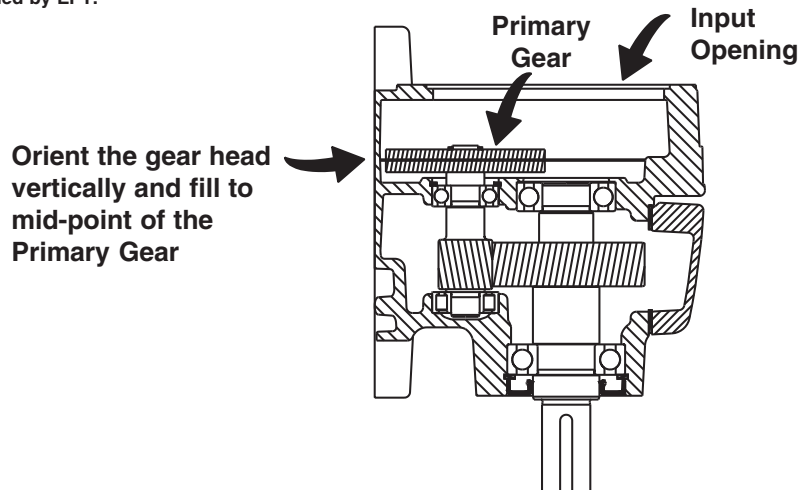



COMBINED UNITS

CbN
SERIES 3000

Lubrication

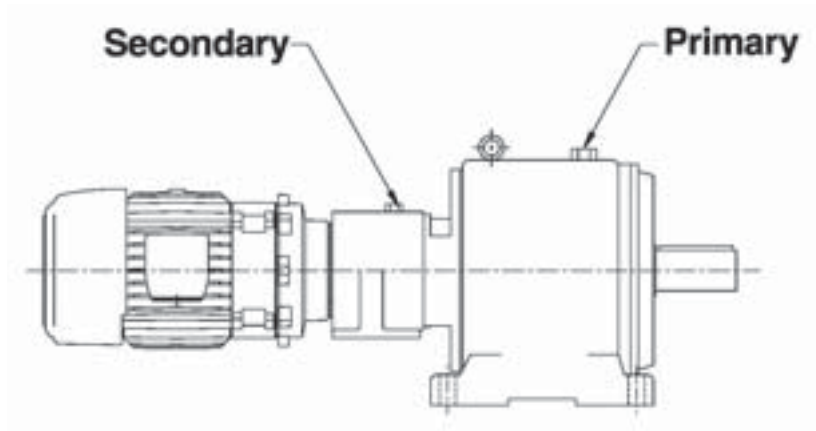

FOOT MOUNTED COMBINED UNITS (U.S. QUARTS)

Gear Frame	Mounting Positions											
	B3		B8		B6		B7		V5		V6	
	Prim.	Sec.	Prim.	Sec.	Prim.	Sec.	Prim.	Sec.	Prim.	Sec.	Prim.	Sec.
3254	0.95	*	2.3	*	2.4	*	1.6	*	2.4	*	2.65	*
3255	0.95	*	2.3	*	2.4	*	1.6	*	2.4	*	2.65	*
3374	1.5	*	5	*	4.6	*	2.9	*	4.7	*	4.4	*
3375	1.5	*	5	*	4.6	*	2.9	*	4.7	*	4.4	*

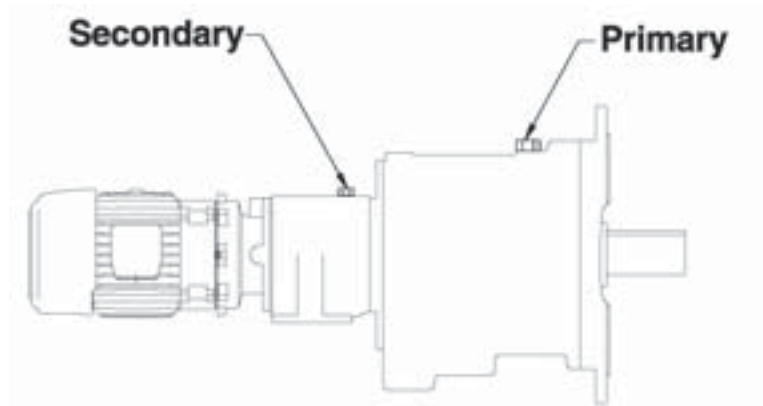

FLANGED MOUNTED COMBINED UNITS (U.S. QUARTS)

Gear Frame	Mounting Positions					
	B5		V1		V3	
	Prim.	Sec.	Prim.	Sec.	Prim.	Sec.
3254	0.95	*	2.4	*	2.65	*
3255	0.95	*	2.4	*	2.65	*
3374	1.5	*	4.7	*	4.4	*
3375	1.5	*	4.7	*	4.4	*

* See illustration on previous page.



Modifications, Options and Accessories

INVERTER DUTY GEARMOTORS

Many Series 3000 three phase gearmotors now incorporate upgraded ALLGUARD wire and insulating materials for inverter service. A one year warranty will be extended for 2:1 (60 - 30 Hz) constant torque for standard efficiency design motors and 3:1 (60 - 20 Hz) constant torque for premium efficiency design motors providing the following conditions are met:

- motor is non-hazardous 3 phase > 48 frame
- cable length to controller ≤ 100 ft
- line volts is ≤ 480 VAC
- thermal protection is not required

For all other conditions of operation including up to 575 VAC and for hazardous environment services, select a Varidyne inverter duty motor design. These designs include thermostats in winding, a 3 year warranty on the motor, and full compliance with NEMA MG1 Part 31.

MOTOR MODIFICATIONS

M1 BRAKES

Design

These mounted brakes have a direct acting, spring set, electromagnetically released disc design. When power to the brake motor is interrupted, the brake will immediately set and hold. When power is restored, the brake will automatically release.

Brake torque must be specified when ordering. Table 1 gives brake torque for stopping and holding loads not greater than full load motor torque. An asterisk indicates borderline maximum ratings and should be considered only for holding loads. Refer to office applications involving high inertia loads or frequent starts and stops.

Enclosures

Standard - Suitable for most indoor non-hazardous applications. Stock SHUR - STOP brakes have this enclosure.

Waterproof / Dust-tight - For applications requiring additional brake protection such as Washdown or CORRO-DUTY. Not suitable for hazardous Class 2 dust applications. Subject to production lead time.

Explosionproof - When a brake is to be mounted on an explosionproof gearmotor, the brake must have UL approval equal to that of the motor end. Brakes are rated class I group D, class II groups F & G temperature code T3B. Subject to production leadtime.

Operating Voltage

Production brakes through 15 lb. ft. are supplied with 230/460 volt coils. Brakes 25 lb. ft. and larger are supplied with 460 volt coils. For brakes to operate at a different frequency or voltage, or for brakes to operate from a separate power supply, refer to EPT Technical Service. Brakes are furnished with leads suitable for external connection.

Mounting

Brakes listed in Table 1 are motor mounted. Brakes through 6 lb. ft. are suitable for all mounting positions. For brakes 10 through 35 lb. ft., specify mounting orientation of brake gearmotor. Where vertical mounting of brakes 50 lb. ft. or larger is required, refer to EPT Technical Service with mounting and application details.

TABLE 1

MAX. HP RATINGS - HIGH SPEED INPUT				BRAKE
4 POLE 1800 RPM	4 POLE 1500 RPM	6 POLE 1200 RPM	6 POLE 1000 RPM	TORQUE (ft-lbs)
1	3/4	1/2	1/2	3
2	1 1/2	1	1	6
3	2	2	1 1/2*	10
5	3	3	2	15
7 1/2	5	5	3	25
10	10*	7 1/2	5	35
15	10	10	7 1/2	50

*Indicates borderline maximum rating for holding loads only.



MOTOR MODIFICATIONS CONTINUED

M2 PREMIUM EFFICIENCY

Premium efficiency motor designs are available starting at 1 HP to meet customer specifications or NRCan legislation. CORRO-DUTY motor ≥ 3 HP and all inverter duty motors meet premium efficiency. TEFC and CORRO-DUTY motors ends from 1 through 2 HP are design C and therefore are exempt from NRCan efficiency requirements.

M3 MULTI-SPEED (3 PHASE ONLY)

Gearmotors with 1800 RPM motors as standard can be supplied with two speed, one winding, constant torque, 1800/900 RPM, 1.0 service factor, TEFC motor ends. Note that change in motor frame may change gearbox size. Thus if gear frame is not within allowable range, it may be necessary to change gear frame size.

TABLE 2

HP	FRAME	ALLOWABLE GEAR FRAMES
.33 / .16	56	30 - 33
.50 / .25	56	30 - 33
.75 / .38	143T	30 - 33
1.0 / .50	145T	30 - 33
1.5 / .75	145TY	30 - 33
2.0 / 1.0	182T	31 - 33
3.0 / 1.5	184T	31 - 33
5 / 2.5	215T	32 - 33
7.5 / 3.75	254T	33
10 / 5	256T	33

M4 CANOPY CAP.

A canopy cap can be supplied for protection from dripping liquids entering fan end of gearmotor when mounted in a motor fan up position (V1, V5).

MOTOR MODIFICATIONS CONTINUED

M5 FREQUENCY - 50 Hz

Motors for operation at 3 phase 50 Hz are available. Standard 50 Hz voltage (detailed in M6) do not require voltage modification. The published output speed based on 1750 RPM input will be reduced by a factor of (1.2) at the same gear ratio. EXAMPLE: 100 RPM output, 60 Hz, 1750 RPM input is 83 RPM output, 50 Hz, 1450 RPM input.

M6 VOLTAGE (3 PHASE ONLY)

Standard voltages available are listed in the table below. Other voltages are available and must be specified at order entry and require special voltage adder.

FREQUENCY	3 PHASE VOLTAGES THRU 30 HP
60 Hz	200, 230, 230/460, 460, 575
50 Hz	200, 220, 230, 220/380, 220/440, 380, 415, 460, 500, 575

M7 INSULATION

Standard 3 phase TEFC and CORRO-DUTY motor ends have premium class F insulation standard. Single phase TEFC and explosionproof motor ends have class B insulation as standard. Class H insulation and tropical protection are available from production on 3 phase motors only (class H not available on explosion proof).

M8 SPACE HEATERS

Space heaters are recommended for gearmotors installed in damp locations to prevent condensation on the motor windings when the motor is not operating. Leads are brought to the standard motor conduit box. Space heater voltage (115, 230, 460 volts) must be specified when order is entered.

M9 THERMAL PROTECTION - Thermostats

This protection uses a bi-metal disc thermostat, embedded in the motor winding, connected into the holding circuit of the motor starter. The sensor opens the control circuit, shutting down the motor on over temperature. Thermostats give protection for running overload, abnormally high ambient, voltage unbalance, high or low voltage, and ventilation failure. Thermostats will not give protection for locked rotor, starting overload, and single phasing.

M10 THERMAL PROTECTION - Therma-Sentry

Therma-Sentry is a full protection system which consists of a solid state electronic controller and thermistor temperature sensors embedded in the motor winding. Therma-Sentry gives protection for all the abnormal conditions of thermostats, plus protection against locked rotor, starting overload, and single phasing. The Therma-Sentry system requires only two leads to connect to the starter panel. Therma-Sentry controller is supplied loose to be separately mounted and separately excited.



Modifications, Options and Accessories

GEAR MODIFICATIONS

M11 CORRO-DUTY

CORRO-DUTY gear reducers are designed for applications in food processing, chemical, poultry and other industries where a gear reducer will be subjected to extreme humidity, washdown steam, detergents, and mild acids. Construction of CORRO-DUTY gear reducers includes normally closed gearcase (31 to 33) breather; exterior of gear painted with corrosion resistant vinyl co-polymer alkyd grey paint. USDA approved white paint is also available.

M12 BREATHER (Normally closed type)

A normally closed breather is available for applications which could contaminate lubricant, such as flying dust. This is supplied standard on frames 31 thru 33.

M13 NPT ADAPTER

These adapters convert metric threads of breather, drain and/or oil level holes in the reducer to standard NPT threads. They are required for customer additions of site glasses, sight tubes, special breathers, and other plumbing accessories. The adapter(s) is supplied loose for mounting by others.

	SIZE	PART NUMBER
31 - 33	1/4" NPFT	0436216

GEARMOTOR MODIFICATIONS

FACE AND FLANGED OUTPUT

(Designated under mounting config.)

Gear ends with face or flanged output are available from stock. Refer to page 12 and individual dimension pages for option based on gear size and reductions.

SYNTHETIC OIL

CbN gearmotors in frames 30 thru 33 are supplied factory filled with a premium synthetic oil. Refer to page 17 for complete details of lubricants.

M15 EXPORT BOXING

Export boxing can be provided for "underdeck" transport. When the quantity of CbN gearmotors exceeds five(s) units, refer to the Sales department for most economical accommodations.

M16 SPECIAL NAMEPLATE

Units can be provided with limited additional special information on the standard product nameplate. When requested, a special nameplate may be provided, stamped with custom markings.



GEARMOTORS

CbN
SERIES 3000

AGMA Application Classification

U: Uniform load M: Moderate shock load V: Heavy shock load

Application	Load	Class		Application	Load	Class		Application	Load	Class	
		Up to 10 hrs/day	Over 10 hrs/day			Up to 10 hrs/day	Over 10 hrs/day			Up to 10 hrs/day	Over 10 hrs/day
AGITATORS				BUCKET				CONVEYORS - Uniformly			
Paper Mills	M	II	II	Conveyors, Uniform	U	I	II	Loaded or Fed: Apron, Ass-			
Pure Liquids	U	I	II	Conveyors, Heavy Duty	M	II	II	sembly, Belt, Bucket, Chain,			
Liquids & Solids	M	II	II	Elevators Cont.	U	I	II	Flight, Oven, Screw	U	I	II
Liquids - Variable Density	M	II	II	Elevators Uniform	U	I	II				
				Elevators, Heavy Duty	M	II	II	CONVEYORS - Heavy Duty			
APRON CONVEYORS				CALENDERS				Not Uniformly Fed: Apron,			
Uniformly Loaded or Fed	U	I	II	Paper	U	-	II	Assembly, Belt, Bucket,			
Heavy Duty	M	II	II	Super (Paper)	U	-	II	Chain, Flight, Oven, Screw	M	II	II
APRON FEEDERS	M	II	II	Rubber	M	II	II	Live Roll (Package)	U	I	II
				Textile	M	II	II	Reciprocating, shaker	V	III	III
ASSEMBLY CONVEYORS				CANE KNIVES	M	II	II	COOKERS (Brewing &			
Uniformly Loaded or Fed	U	I	II					Distilling) (Food)	U	I	II
Heavy Duty	M	II	II	CAN FILLING MACHINES	U	I	II				
BALL MILLS	V	III	III					COOLING TOWER FANS			
				CARD MACHINES (Textile)	M	II	II	Induced Draft	M	II	II
BARKING								Forced Draft	Refer to Tech. Service		
Drums	V	-	III	CAR DUMPERS	V	III	-	COUCH (Paper)	M	-	II
Hydraulic Auxiliaries	V	-	III								
Mechanical	V	-	III	CAR PULLERS	M	II	-	CRANES & HOISTS			
BAR SCREENS (Sewage)	U	I	II					Main Hoists			
				CEMENT KILNS	Refer to Tech. Service			Heavy Duty	V	III	III
BATCHERS (Textile)	M	II	II					Medium Duty	M	II	II
				CENTRIFUGAL				Reversing	V	II	II
BEATERS & PULPERS (Paper)	U	-	II	Blowers, Compressors, Dis-	U	I	II	Skip Hoists	M	II	II
				charge Elevators or Pumps				Trolley Drive	M	II	II
BELT CONVEYORS								Bridge Drive	M	II	II
Uniformly Loaded or Fed	U	I	II	CHAIN CONVEYORS				CRUSHERS			
Heavy Duty	M	II	II	Uniformly Loaded or Fed	U	I	II	Ore or Stone	V	III	III
				Heavy Duty	M	II	II				
BELT FEEDERS	M	II	II	CHEMICAL FEEDERS (Sewage)	U	I	II	CUTTERS (Paper)	V	-	III
BENDING ROLLS (Machine)	M	II	II	CLARIFIERS	U	I	II	CYLINDERS (Paper)	M	-	II
BLEACHERS (Paper)	M	-	II	CLASSIFIERS	M	II	II	DEWATERING SCREENS (Sewage)	M	II	II
BLOWERS				CLAY WORKING INDUSTRY				DISC FEEDERS	U	I	II
Centrifugal	U	I	II	Brick Press	V	III	III				
Lobe	M	II	II	Briquette Machine	V	III	III	DISTILLING	(See Brewing)		
Vane	U	I	II	Clay Working Machinery	M	II	II				
				Pug Mill	M	II	II	DOUBLE ACTING PUMPS			
BOTTLING MACHINERY	U	I	II					2 or more Cylinders	M	II	II
				COLLECTORS (Sewage)	U	I	II	Single Cylinder	Refer to Tech. Service		
BREWING & DISTILLING								DOUGH MIXER (Food)	M	II	II
Bottling Machinery	U	I	II	COMPRESSORS							
Brew Kettles, Cont. Duty	U	-	II	Centrifugal	U	I	II	DRAW BENCH (Metal Mills)			
Can Filling Machines	U	I	II	Lobe	M	II	II	Carriage & Main Drive	V	III	III
Cookers - Cont. Duty	U	-	II	Reciprocating,							
Mash Tubs - Cont. Duty	U	-	II	Multi - Cylinder	M	II	II	DREDGES			
Scale Hoppers -				Single - Cylinder	V	III	III	Cable Reels	M	II	-
Frequent Starts	M	II	II					Conveyors	M	II	II
BRICK PRESS (Clay Working)	V	III	III	CONCRETE MIXERS				Cutter Head Drives	V	III	III
				Continuous	M	II	II	Jig Drives	V	III	III
BRIQUETTE MACHINES (Clay Working)	V	III	III	Intermittent	U	I	-	Maneuvering Winches	M	II	-
								Pumps	M	II	II
				CONVERTING MACHINES (Paper)	M	-	II	Screen Drives	V	III	III
								Stackers	M	II	II
								Utility Winches	M	II	-



GEARMOTORS

CbN SERIES 3000

AGMA Application Classification

U: Uniform load M: Moderate shock load V: Heavy shock load

Application	Load	Class		Application	Load	Class		Application	Load	Class	
		Up to 10 hrs/day	Over 10 hrs/day			Up to 10 hrs/day	Over 10 hrs/day			Up to 10 hrs/day	Over 10 hrs/day
DRYERS (Paper)	U	-	II	HAMMER MILLS	V	III	III	MACHINE TOOLS			
DRYERS & COOLERS (Mills, Rotary)	M	II	II	INDUCED DRAFT FANS	M	II	II	Auxiliary Drives	U	I	II
DYEING MACHINERY (Textile)	M	II	II	JORDANS (Paper)	U	-	II	Bending Rolls	M	II	II
ELEVATORS				KILNS (Mills, Rotary) Cement	M	II	II	Main Drives	M	II	II
Bucket - Uniform Load	U	I	II					Notching Press (Belted)	Refer to Tech. Service		
Bucket - Heavy Duty	M	II	II	LAUNDRY WASHERS & TUMBLERS	M	II	II	Plate Planers	V	III	III
Bucket - Continuous	U	I	II	LINE SHAFTS				Punch Press (Geared)	V	III	III
Centrifugal Discharge	U	I	II	Heavy Shock Load	V	III	III	Tapping Machines	V	III	III
Escalators	U	I	II	Moderate Shock Load	M	II	II				
Freight	M	II	II	Uniform Load	U	I	II	MANGLE (Textile)	M	II	II
Gravity Discharge	U	I	II	LIVE ROLL CONVEYORS				MASH TUBS (Brewing & Distilling)	U	-	II
Man Lifts, Passenger	Refer to Tech. Service			Package	U	I	II	MEAT GRINDER (Food)	M	II	II
ESCALATORS	U	I	II	LOBE BLOWER OR COMPRESSORS	M	II	II	METAL MILLS			
FANS				LOG HAULS (Paper & Lumber)	V	III	III	Draw Bench Carriages & Main Drives	V	III	III
Centrifugal	M	II	II	LOOMS (Textile)	M	II	II	Forming Machines	V	III	III
Cooling Towers				LUMBER INDUSTRY				Pinch, Dryer & Scrubber			
Induced Draft	M	II	II	Barkers - Spindle Feed	V	II	III	Rolls Reversing	Refer to Tech. Service		
Forced Draft	Refer to Tech. Service			Barkers - Main Drive	V	III	III	Slitters	M	II	II
Induced Draft	M	II	II	Carriage Drive	Refer to Tech. Service			Table Conveyors, Non-Reversing	M	II	III
Large (Mine, etc.)	M	II	II	Conveyors				Reversing	V	-	III
Large Industrial	M	II	II	Burner	V	II	III	Wire Drawing & Flattening Machines	M	II	III
Light (Small Diameter)	U	I	II	Main or Heavy Duty	V	II	III	Wire Winding Machines	M	II	II
FEEDERS				Main Log	V	III	III				
Apron, belt	M	II	II	Re-Saw Merry-Go-Round	V	II	III	MILLS, ROTARY TYPE			
Disc	U	I	II	Slab	V	III	III	Ball, Pebble, Rod	V	III	III
Reciprocating	V	III	III	Transfer	V	II	III	Cement Kilns	Refer to Tech. Service		
Screw	M	II	II	Chains - Floor	V	II	III	Coolers, Dryers, Kilns	V	II	II
FELT				Chains - Green	V	II	III	Tumbling Barrels	V	III	III
Stretchers (Paper)	U	-	II	Cut-Off Saws-Chain	V	II	III				
Whippers (Paper)	U	-	II	Cut-Off Saws-Drag	V	II	III	MIXERS (Also see Agitators)			
FLIGHT				Debarking Drums	V	III	III	Concrete - Continuous	M	II	II
Conveyors, Uniform	U	I	II	Feeds - Edger	V	II	III	Concrete - Intermittent	M	I	-
Conveyors, Heavy	M	II	II	Feeds - Gang	V	III	III	Constant Density	U	I	II
FOOD INDUSTRY				Feeds - Trimmer	V	II	III	Variable Density	M	II	II
Beet Slicers	M	II	II	Log Deck	V	III	III	NAPPERS (Textile)	M	II	II
Bottling, Can Filling Mach.	U	I	II	Log Hauls - Incline, Well Type	V	III	III	OIL INDUSTRY			
Cereal Cookers	U	I	II	Log Turning Devices	V	III	III	Chillers	M	II	II
Dough Mixers	M	II	II	Planner Feed	V	II	III	Oil Well Pumping	Refer to Tech. Service		
Meat Grinders	M	II	II	Planer Tilting Hoists	V	II	III	Paraffin Filter Press	M	II	II
FORMING MACHINES (Metal Mills)	V	III	III	Rolls - Live-Off Bearing				Rotary Kilns	M	II	II
GENERATORS (Not welding)	U	I	II	Roll Cases	V	III	III	ORE CRUSHERS	V	III	III
GRAVITY DISCHARGE ELEVATORS	U	I	II	Sorting Table	V	II	III	OVEN CONVEYORS			
GRIT COLLECTORS (Sewage)	U	I	II	Tipple Hoist	V	II	III	Uniform	U	I	II
				Transfers - Chain	V	II	III	Heavy Duty	M	II	II
				Transfers - Craneway	V	II	III				
				Tray Drives	V	II	III				



AGMA Application Classification

U: Uniform load M: Moderate shock load V: Heavy shock load

Application	Load	Class		Application	Load	Class		Application	Load	Class	
		Up to 10 hrs/day	Over 10 hrs/day			Up to 10 hrs/day	Over 10 hrs/day			Up to 10 hrs/day	Over 10 hrs/day
PAPER MILLS				ROD MILLS	V	III	III	SOAPERS (Textile)	M	II	II
Agitator (Mixers)	M	II	II					SPINNERS (Textile)	M	II	II
Barker - Auxiliaries - Hyd.	V	-	III	ROTARY				STEERING GEARS	M	II	II
Barker, Mechanical	V	-	III	Pumps, Gear, Lobe, Vane	U	I	II	STOCK CHESTS (Paper)	U	-	ii
Barking Drum	V	-	III	Screens (Sand or Gravel)	V	II	II	STOKERS	U	I	II
Beater & Pulper	M	-	II					STONE CRUSHERS	V	III	III
Bleacher	M	-	II	RUBBER INDUSTRY				SUCTION ROLLS (Paper)	U	-	II
Calenders	M	-	II	Mixer	V	III	III	TABLE CONVEYORS (Metal Mills) Non-Reversing	V	II	III
Calenders - Super	M	-	II	Rubber Calender	M	II	II	Reversing	V	-	III
Converting Mach.- Except Cutters - Platers	M	-	II	Rubber Mill (2 or more)	M	II	II	TENTER FRAMES (Textile)	M	II	II
Conveyors	M	-	II	Sheeter	M	II	II	TEXTILE INDUSTRY			
Couch	M	-	II	Tire Building Machines	Refer to Tech. Service			Batchers	M	II	II
Cutters, Platers	V	-	III	Tire, Tube Press Openers	Refer to Tech. Service			Calenders	M	II	II
Cylinders	U	-	II	Tubers & Strainers	M	II	II	Card Machines	M	II	II
Dryers	U	-	II					Cloth Finishing Mach. (Calenders, Dryers, Pads, Tenter, Washers)	M	II	II
Felt Stretchers	U	-	II	SAND MULLERS	Refer to Tech. Service			Dry Cans	M	II	II
Felt Whippers	V	-	III					Dyeing Machinery	M	II	II
Jordans	M	-	II	SCREENS				Knitting Machinery	Refer to Tech. Service		
Log Haul	V	-	III	Air Washing	U	I	II	Looms, Mangles, Nappers	M	II	II
Presses	M	-	II	Rotary - Sand or Gravel	M	II	II	Range Drives	Refer to Tech. Service		
Pulp Machine Reels	M	-	II	Traveling Water Intake	U	I	II	Soapers, Spinners	M	II	II
Stock Chests	M	-	II					Tenter Frames	M	II	II
Suction Rolls	M	-	II	SCREW CONVEYORS				Winders	M	II	II
Washers & Thickeners	M	-	II	Uniform	U	I	II	Yarn Preparatory Mach. (Cards, Spinners, Slashers)	M	II	II
Winders	M	-	II	Heavy Duty or Feeder	M	II	II				
								THICKENERS (Sewage)	M	II	II
PASSENGER ELEVATORS	Refer to Tech. Service			SCUM BREAKERS (Sewage)	M	II	II	TUMBLING BARRELS	V	III	III
PEBBLE MILLS	V	III	III					VACUUM FILTERS (sewage)	M	II	II
PLATE PLANERS	V	III	III	SEWAGE DISPOSAL				VANE BLOWERS	U	I	II
PRESSES (Paper)	V	-	III	Aerators	Refer to Tech. Service			WINCHES (Dredges)	M	II	-
PROPORTIONING PUMPS	M	II	II	Bar Screens	U	I	II	WINDERS (Paper)	U	-	II
PUB MILLS (CLAY)	M	II	II	Chemical Feeders	U	I	II	(Textile)	M	II	II
PULLERS (Barge Haul)	V	III	III	Collectors	U	I	II	WINDLASS	M	II	II
PULP MACHINE REELS	U	-	II	Dewatering Screens	M	II	II	WIRE			
				Grit Collectors	U	I	II	Drawing Machines	M	II	III
PUMPS				Scum Breakers	M	II	II	Winding Machines	M	II	II
Centrifugal	U	I	II	Slow or Rapid Mixers	M	II	II				
Proportioning	M	II	II	Sludge Collectors	U	I	II				
Reciprocating				Thickeners	M	II	II				
Single Act., 3 or more cyl.	M	II	II	Vacuum Filters	M	II	II				
Double Act., 2 or more cyl.	M	II	II								
Single Act., 1 or 2 cyl.	Refer to Tech. Service			SHAKER CONVEYORS	V	III	III				
Rotary: Gear, Lobe, Vane	U	I	II	SHEETERS (Rubber)	M	II	II				
PUNCH PRESS (Gear Driven)	V	III	III	SINGLE ACTING PUMP							
				1 or 2 Cylinders	Refer to Tech. Service						
RECIPROCATING				3 or more Cylinders	M	II	II				
Conveyors, Feeders	V	III	III								
				SKIP HOIST	M	II	II				
RECIPROCATING COM-PRESSORS				SLAB PUSHERS	M	II	II				
Multi-Cylinder	M	II	II	SLITTERS (Metal)	M	II	II				
Single cylinder	V	III	III	SLUDGE COLLECTORS (Sewage)	U	I	II				

Applications not listed in this table or where the user has data indicating the severity of his usage to be greater than average should be referred to Technical Services.



GEARMOTORS

CbN3000 SERIES

1/6 HP

General Specifications: Totally enclosed, 60 hertz, 40°C ambient, continuous duty.

REFER TO SERIES 1000 FOR RATIOS < 80:1

Output RPM	AGMA Class	Service Factor	Output Torque in-lb	OHL lb	Nominal Ratio	Frame Size Gear	Frame Size Motor	Std. Motor Types ◊
21	I,II,III	3.2	469	1219	80	3133	48	T, S
20	I,II,III	3.1	496	1219	90	3133	48	T, S
17	I,II,III	2.9	562	1219	100	3133	48	T, S
16	I,II,III	2.7	621	1219	112	3133	48	T, S
14	I,II,III	2.5	709	1219	125	3133	48	T, S
12	I,II,III	2.2	813	1219	140	3133	48	T, S
11	I,II,III	2.0	884	1219	160	3133	48	T, S
10	I,II	1.7	1037	1219	180	3133	48	T, S
9	I,II	1.6	1114	1219	200	3133	48	T, S

1/4 HP

REFER TO SERIES 1000 FOR RATIOS < 50:1

Output RPM	AGMA Class	Service Factor	Output Torque in-lb	OHL lb	Nominal Ratio	Frame Size Gear	Frame Size Motor	Std. Motor Types ◊
35	I,II,III	3+	425	1219	50	3132	48	T, S
30	I,II,III	2.8	489	1219	56	3133	48	T, S
26	I,II,III	2.5	558	1219	63	3133	48	T, S
25	I,II,III	2.4	588	1219	71	3133	48	T, S
21	I,II,III	2.2	703	1219	80	3133	48	T, S
20	I,II,III	2.1	744	1219	90	3133	48	T, S
17	I,II	1.9	843	1219	100	3133	48	T, S
16	I,II	1.8	932	1219	112	3133	48	T, S
14	I,II	1.6	1063	1219	125	3133	48	T, S
12	I,II	1.5	1219	1219	140	3133	48	T, S
10.9	I,II	1.4	1326	1219	160	3133	48	T, S
9.5	I	1.2	1555	1219	180	3133	48	T, S
8.6	I	1.1	1670	1219	200	3133	48	T, S

◊ **Standard Motor Types** (see page 13 for product codes)
 T TEFC, three phase, 208-230/460 or 575 volts
 S TEFC, single phase, 115/230 volts



GEARMOTORS

CbN SERIES 3000

1/3 HP

General Specifications: Totally enclosed, 60 hertz, 40°C ambient, continuous duty.

Output RPM	AGMA Class	Service Factor	Output Torque in-lb	OHL Δ lb	Nominal Ratio	Frame Size Gear	Motor	Std. Motor Types ◊
1411	I,II,III	3+	14	172	1.25	3001	56	T,S,C,X°,IG
1199	I,II,III	3+	17	181	1.4	3001	56	T,S,C,X°,IG
1136	I,II,III	3+	18	184	1.6	3001	56	T,S,C,X°,IG
956	I,II,III	3+	21	193	1.8	3001	56	T,S,C,X°,IG
893	I,II,III	3+	23	197	2	3001	56	T,S,C,X°,IG
799	I,II,III	3+	26	204	2.24	3001	56	T,S,C,X°,IG
686	I,II,III	3+	30	213	2.5	3001	56	T,S,C,X°,IG
636	I,II,III	3+	32	217	2.8	3001	56	T,S,C,X°,IG
540	I,II,III	3+	38	227	3.15	3001	56	T,S,C,X°,IG
482	I,II,III	3+	42	234	3.55	3001	56	T,S,C,X°,IG
429	I,II,III	3+	47	241	4	3001	56	T,S,C,X°,IG
382	I,II,III	3+	53	248	4.5	3001	56	T,S,C,X°,IG
338	I,II,III	3.0	60	255	5	3001	56	T,S,C,X°,IG
338	I,II,III	3.0	68	262	5.6	3001	56	T,S,C,X°,IG
273	I,II,III	3.0	75	267	6.3	3001	56	T,S,C,X°,IG
242	I,II,III	3.0	84	274	7.1	3001	56	T,S,C,X°,IG
215	I,II,III	2.7	95	280	8	3001	56	T,S,C,X°,IG
204	I,II,III	3+	98	522	9	3012	56	T,S,C,X°,IG
172	I,II,III	3+	116	550	10	3012	56	T,S,C,X°,IG
160	I,II,III	3+	125	562	11.2	3012	56	T,S,C,X°,IG
143	I,II,III	3+	140	582	12.5	3012	56	T,S,C,X°,IG
123	I,II,III	3+	162	600	14	3012	56	T,S,C,X°,IG
114	I,II,III	3+	175	600	16	3012	56	T,S,C,X°,IG
97	I,II,III	3+	206	600	18	3012	56	T,S,C,X°,IG
86	I,II,III	3+	231	600	20	3012	56	T,S,C,X°,IG
77	I,II,III	3.0	260	600	22.4	3012	56	T,S,C,X°,IG
68	I,II,III	2.7	292	600	25	3012	56	T,S,C,X°,IG
61	I,II,III	2.4	329	600	28	3012	56	T,S,C,X°,IG
52	I,II,III	2.1	371	600	31.5	3012	56	T,S,C,X°,IG
49	I,II	1.9	408	1211	35.5	3012	56	T,S,C,X°,IG
43	I,II	1.7	460	600	40	3012	56	T,S,C,X°,IG
45	III	3+	443	1211	40	3132	56	T,S,C,X,IG
39	I,II	1.5	517	600	45	3012	56	T,S,C,X°,IG
39	III	3.0	508	1260	45	3132	56	T,S,C,X,IG
36	I,II	1.6	549	600	50	3013	56	T,S,C,X°,IG
36	III	3.0	561	1296	50	3132	56	T,S,C,X,IG
32	I,II	1.4	615	600	56	3013	56	T,S,C,X°,IG
30	III	2.1	646	1345	56	3133	56	T,S,C,X,IG
27	I	1.2	716	600	63	3013	56	T,S,C,X°,IG
27	II	1.9	729	1345	63	3133	56	T,S,C,X,IG

◊ **Standard Motor Types** (see page 13 for product codes)

- T TEFC, three phase, 208-230/460 or 575 volts
- S TEFC, single phase, 115/230 volts
- C Corro-duty, three phase, 230/460 or 575V
- X° Explosion proof, CL1 Grp D, Three phase, 230/460 or 575V
- X Explosion proof, CI 1 Grp D, CI 2 grps F&G, three phase, 230/460 or 575V
- IG INTELLIGEAR variable speed for 1/230VAC, 3/230V, or 3/460V power supplies



GEARMOTORS

CbN
SERIES **3000**

1/3 HP (CONTINUED)

General Specifications: Totally enclosed, 60 hertz, 40°C ambient, continuous duty.

Output RPM	AGMA Class	Service Factor	Output Torque in-lb	OHL Δ lb	Nominal Ratio	Frame Size Gear	Motor	Std. Motor Types ◊
25	I	1.1	772	600	71	3013	56	T,S,C,X°,IG
25	II	1.8	774	1345	71	3133	56	T,S,C,X,IG
25	III	3+	766	1610	71	3253	56	T,S,C,X,IG
22	I	1.0	908	600	80	3013	56	T,S,C,X°,IG
22	II	1.6	919	1345	80	3133	56	T,S,C,X,IG
22	III	3+	870	1610	80	3253	56	T,S,C,X,IG
20	I,II	1.6	919	1345	90	3133	56	T,S,C,X,IG
20	III	3+	966	1610	90	3253	56	T,S,C,X,IG
18	I,II	1.5	1110	1345	100	3133	56	T,S,C,X,IG
18	III	3+	1097	1610	100	3253	56	T,S,C,X,IG
16	I,II	1.4	1239	1345	112	3133	56	T,S,C,X,IG
16	III	3+	1221	1610	112	3253	56	T,S,C,X,IG
14	I	1.2	1390	1345	125	3133	56	T,S,C,X,IG
14	II,III	2.9	1374	1610	125	3253	56	T,S,C,X,IG
12	I	1.1	1609	1345	140	3133	56	T,S,C,X,IG
12	II,III	2.5	1610	1610	140	3253	56	T,S,C,X,IG
11	I	1.0	1767	1345	160	3133	56	T,S,C,X,IG
11	II,III	2.3	1777	1610	160	3253	56	T,S,C,X,IG
10	I,II,III	2.1	1949	1610	180	3253	56	T,S,C,X,IG
8.6	I,II	1.8	2276	1610	200	3253	56	T,S,C,X,IG
8.6	III	2.7	2239	2305	200	3363	56	T,S,C,X,IG
7.9	I,II	1.8	2416	1610	224	3254	56	T,S,C,X°,IG
7.9	III	3+	2416	2905	224	3374	56	T,S,C,X°,IG
7.1	I,II	1.5	2701	1610	250	3254	56	T,S,C,X°,IG
7.1	III	2.6	2701	2905	250	3374	56	T,S,C,X°,IG
6.7	I,II	1.4	2843	1610	280	3254	56	T,S,C,X°,IG
6.7	III	2.5	2843	2905	280	3374	56	T,S,C,X°,IG
5.7	I	1.2	3368	1610	315	3254	56	T,S,C,X°,IG
5.7	II,III	2.1	3368	2905	315	3374	56	T,S,C,X°,IG
5.3	I	1.1	3619	1610	355	3254	56	T,S,C,X°,IG
5.3	II,III	2.0	3619	2905	355	3374	56	T,S,C,X°,IG
4.7	I	1.0	4046	1610	400	3254	56	T,S,C,X°,IG
4.7	II	1.7	4046	2905	400	3374	56	T,S,C,X°,IG
4.1	I,II	1.5	4713	2905	450	3374	56	T,S,C,X°,IG
3.8	I,II	1.4	5073	2905	500	3374	56	T,S,C,X°,IG
3.2	1	1.2	5970	2905	560	3374	56	T,S,C,X°,IG
2.9	I	1.1	6692	2905	630	3374	56	T,S,C,X°,IG

◊ **Standard Motor Types** (see page 13 for product codes)

- T TEFC, three phase, 208-230/460 or 575 volts
- S TEFC, single phase, 115/230 volts
- C Corro-duty, three phase, 230/460 or 575V
- X° Explosion proof, CL1 Grp D, Three phase, 230/460 or 575V
- X Explosion proof, CI 1 Grp D, CI 2 grps F&G, three phase, 230/460 or 575V
- IG INTELLIGEAR variable speed for 1/230VAC, 3/230V, or 3/460V power supplies



GEARMOTORS

CbN SERIES 3000

1/2 HP

General Specifications: Totally enclosed, 60 hertz, 40°C ambient, continuous duty.

Output RPM	AGMA Class	Service Factor	Output Torque in-lb	OHL lb	Nominal Ratio	Frame Size Gear	Motor	Std. Motor Types ◊
1411	I,II,III	3+	22	163	1.25	3001	56	T,S,C,X°,IG
1199	I,II,III	3+	26	171	1.4	3001	56	T,S,C,X°,IG
1136	I,II,III	3+	27	173	1.6	3001	56	T,S,C,X°,IG
956	I,II,III	3+	32	182	1.8	3001	56	T,S,C,X°,IG
893	I,II,III	3+	35	185	2	3001	56	T,S,C,X°,IG
799	I,II,III	3+	39	191	2.24	3001	56	T,S,C,X°,IG
686	I,II,III	3+	45	198	2.5	3001	56	T,S,C,X°,IG
636	I,II,III	3+	49	202	2.8	3001	56	T,S,C,X°,IG
540	I,II,III	3+	57	209	3.15	3001	56	T,S,C,X°,IG
482	I,II,III	3+	64	214	3.55	3001	56	T,S,C,X°,IG
429	I,II,III	3+	72	220	4	3001	56	T,S,C,X°,IG
382	I,II,III	3+	81	224	4.5	3001	56	T,S,C,X°,IG
338	I,II,III	2.0	91	229	5	3001	56	T,S,C,X°,IG
338	I,II,III	2.0	103	233	5.6	3001	56	T,S,C,X°,IG
273	I,II,III	2.0	113	236	6.3	3001	56	T,S,C,X°,IG
242	I,II,III	2.0	127	239	7.1	3001	56	T,S,C,X°,IG
215	I,II	1.8	143	241	8	3001	56	T,S,C,X°,IG
214	III	3+	141	505	8	3012	56	T,S,C,X°,IG
204	I,II,III	3+	148	513	9	3012	56	T,S,C,X°,IG
172	I,II,III	3+	176	540	10	3012	56	T,S,C,X°,IG
160	I,II,III	3+	189	551	11.2	3012	56	T,S,C,X°,IG
143	I,II,III	3+	211	569	12.5	3012	56	T,S,C,X°,IG
123	I,II,III	3+	246	584	14	3012	56	T,S,C,X°,IG
114	I,II,III	2.9	265	590	16	3012	56	T,S,C,X°,IG
97	I,II,III	2.5	312	600	18	3012	56	T,S,C,X°,IG
86	I,II,III	2.2	350	600	20	3012	56	T,S,C,X°,IG
77	I,II,III	2.0	393	600	22.4	3012	56	T,S,C,X°,IG
68	I,II	1.8	442	600	25	3012	56	T,S,C,X°,IG
69	III	2.0	439	1027	25	3122	56	T,S,C,X,IG
64	III	3+	471	1062	28	3132	56	T,S,C,X,IG
61	I,II	1.6	499	600	28	3012	56	T,S,C,X°,IG
57	I,II,III	3+	528	1097	31.5	3132	56	T,S,C,X,IG
52	I,II	1.4	562	600	31.5	3012	56	T,S,C,X°,IG
49	I	1.3	618	600	35.5	3012	56	T,S,C,X°,IG
49	II,III	2.9	611	1141	35.5	3132	56	T,S,C,X,IG
45	I,II,III	2.7	671	1170	40	3132	56	T,S,C,X,IG
43	I	1.1	697	589	40	3012	56	T,S,C,X°,IG
39	I	1.0	784	572	45	3012	56	T,S,C,X°,IG
39	II,III	2.0	770	1212	45	3132	56	T,S,C,X,IG

◊ **Standard Motor Types** (see page 13 for product codes)

T TEFC, three phase, 208-230/460 or 575 volts

S TEFC, single phase, 115/230 volts

C Corro-duty, three phase, 230/460 or 575V

X° Explosion proof, CL1 Grp D, Three phase, 230/460 or 575V

X Explosion proof, CI 1 Grp D, CI 2 grps F&G, three phase, 230/460 or 575V

IG INTELLIGEAR variable speed for 1/230VAC, 3/230V, or 3/460V power supplies



GEARMOTORS

CbN
SERIES **3000**

1/2 HP (CONTINUED)

General Specifications: Totally enclosed, 60 hertz, 40°C ambient, continuous duty.

Output RPM	AGMA Class	Service Factor	Output Torque in-lb	OHL lb	Nominal Ratio	Frame Size Gear	Motor	Std. Motor Types ◊
36	I	1.1	832	600	50	3013	56	T,S,C,X°,IG
36	II,III	2.0	850	1243	50	3132	56	T,S,C,X, IG
30	I,II	1.4	979	1297	56	3133	56	T,S,C,X, IG
30	III	3+	943	1610	56	3253	56	T,S,C,X,IG
27	I	1.3	1104	1335	63	3133	56	T,S,C,X,IG
27	II,III	3+	1087	1610	63	3253	56	T,S,C,X,IG
25	I	1.2	1172	1345	71	3133	56	T,S,C,X,IG
25	II,III	3.5	1161	1610	71	3253	56	T,S,C,X,IG
22	I	1.1	1392	1345	80	3133	56	T,S,C,X,IG
22	II,III	3+	1318	1610	80	3253	56	T,S,C,X,IG
20	I	1.0	1472	1345	90	3133	56	T,S,C,X,IG
20	II,III	2.7	1464	1610	90	3253	56	T,S,C,X,IG
18	I	1.0	1682	1345	100	3133	56	T,S,C,X,IG
18	II,III	2.4	1663	1610	100	3253	56	T,S,C,X,IG
16	I,II,III	2.2	1850	1610	112	3253	56	T,S,C,X,IG
14.2	I,II	1.9	2081	1610	125	3253	56	T,S,C,X,IG
14.1	III	2.9	2125	2305	125	3363	56	T,S,C,X,IG
12.1	I,II	1.6	2440	1610	140	3253	56	T,S,C,X,IG
12.4	III	2.6	2375	2305	140	3363	56	T,S,C,X,IG
11.0	I,II	1.5	2693	1610	160	3253	56	T,S,C,X,IG
10.8	III	2.2	2743	2305	160	3363	56	T,S,C,X,IG
10.0	I,II	1.4	2953	1610	180	3253	56	T,S,C,X,IG
9.7	III	2.0	3065	2305	180	3363	56	T,S,C,X,IG
8.7	I	1.2	3448	1610	200	3253	56	T,S,C,X,IG
8.7	II	1.8	3393	2305	200	3363	56	T,S,C,X,IG
8.7	III	2.2	3393	2905	200	3373	56	T,S,C,X,IG
7.9	I,II	1.2	3661	1610	224	3254	56	T,S,C,X°,IG
7.9	III	2.1	3661	2905	224	3374	56	T,S,C,X°,IG
7.1	I,II	1.7	4092	2905	250	3374	56	T,S,C,X°,IG
6.7	I,II	1.7	4307	2905	280	3374	56	T,S,C,X°,IG
5.7	I,II	1.4	5103	2905	315	3374	56	T,S,C,X°,IG
5.3	I	1.3	5467	2905	350	3374	56	T,S,C,X°,IG
4.7	I	1.2	6130	2905	400	3374	56	T,S,C,X°,IG
4.1	I	1.0	7140	2905	450	3374	56	T,S,C,X°,IG

◊ **Standard Motor Types** (see page 13 for product codes)

T TEFC, three phase, 208-230/460 or 575 volts

S TEFC, single phase, 115/230 volts

C Corro-duty, three phase, 230/460 or 575V

X° Explosion proof, CL1 Grp D, Three phase, 230/460 or 575V

X Explosion proof, CI 1 Grp D, CI 2 grps F&G, three phase, 230/460 or 575V

IG INTELLIGEAR variable speed for 1/230VAC, 3/230V, or 3/460V power supplies



GEARMOTORS

CbN SERIES 3000

3/4 HP

General Specifications: Totally enclosed, 60 hertz, 40°C ambient, continuous duty.

Output RPM	AGMA Class	Service Factor	Output Torque in-lb	OHL lb	Nominal Ratio	Frame Size Gear	Motor	Std. Motor Types ◊
1411	I,II,III	3+	33	150	1.25	3001	56	T,S,C,X°,IG
1199	I,II,III	3+	39	156	1.4	3001	56	T,S,C,X°,IG
1136	I,II,III	3+	41	158	1.6	3001	56	T,S,C,X°,IG
956	I,II,III	3+	48	165	1.8	3001	56	T,S,C,X°,IG
893	I,II,III	3+	52	167	2	3001	56	T,S,C,X°,IG
799	I,II,III	3+	58	171	2.24	3001	56	T,S,C,X°,IG
686	I,II,III	3+	67	176	2.5	3001	56	T,S,C,X°,IG
636	I,II,III	3+	73	179	2.8	3001	56	T,S,C,X°,IG
540	I,II,III	3+	86	183	3.15	3001	56	T,S,C,X°,IG
482	I,II,III	3+	96	186	3.55	3001	56	T,S,C,X°,IG
429	I,II,III	3+	108	188	4	3001	56	T,S,C,X°,IG
382	I,II,III	3.0	121	190	4.5	3001	56	T,S,C,X°,IG
338	I,II	1.4	137	191	5	3001	56	T,S,C,X°,IG
356	III	3+	130	427	5	3101	56	T,S,C,X,IG
301	I,II	1.4	154	191	5.6	3001	56	T,S,C,X°,IG
308	III	2.9	151	447	5.6	3101	56	T,S,C,X,IG
273	I,II	1.4	169	190	6.3	3001	56	T,S,C,X°,IG
280	III	2.7	165	459	6.3	3101	56	T,S,C,X,IG
242	I	1.3	191	188	7.1	3001	56	T,S,C,X°,IG
237	II,III	3+	180	469	7.1	3012	56	T,S,C,X°,IG
215	I	1.2	215	185	8	3001	56	T,S,C,X°,IG
214	II,III	3+	212	481	8	3012	56	T,S,C,X°,IG
204	I,III,III	3+	223	484	9	3012	56	T,S,C,X°,IG
172	I,III,III	2.9	264	493	10	3012	56	T,S,C,X°,IG
160	I,III,III	2.7	283	495	11.2	3012	56	T,S,C,X°,IG
143	I,III,III	2.4	317	499	12.5	3012	56	T,S,C,X°,IG
123	I,III,III	2.1	369	500	14	3012	56	T,S,C,X°,IG
114	I,II	1.9	398	500	16	3012	56	T,S,C,X°,IG
111	III	3.1	409	869	16	3122	56	T,S,C,X,IG
97	I,II	1.7	468	495	18	3012	56	T,S,C,X°,IG
96	III	2.6	474	903	18	3122	56	T,S,C,X,IG
87	I,II	1.5	525	488	20	3012	56	T,S,C,X°,IG
87	III	2.4	520	925	20	3122	56	T,S,C,X,IG
82	II,III	3.2	520	933	22.4	3132	56	T,S,C,X,IG
77	I	1.3	590	477	22.4	3012	56	T,S,C,X°,IG
69	I	1.2	664	462	25	3012	56	T,S,C,X°,IG
69	II	1.4	597	957	25	3122	56	T,S,C,X,IG
69	III	2.8	658	980	25	3132	56	T,S,C,X,IG
64	II,III	2.5	707	1020	28	3132	56	T,S,C,X,IG

◊ **Standard Motor Types** (see page 13 for product codes)

- T TEFC, three phase, 208-230/460 or 575 volts
- S TEFC, single phase, 115/230 volts
- C Corro-duty, three phase, 230/460 or 575V
- X° Explosion proof, CL1 Grp D, Three phase, 230/460 or 575V
- X Explosion proof, Cl 1 Grp D, Cl 2 grps F&G, three phase, 230/460 or 575V
- IG INTELLIGEAR variable speed for 1/230VAC, 3/230V, or 3/460V power supplies



GEARMOTORS

CbN
SERIES **3000**

3/4 HP (CONTINUED)

General Specifications: Totally enclosed, 60 hertz, 40°C ambient, continuous duty.

Output RPM	AGMA Class	Service Factor	Output Torque in-lb	OHL lb	Nominal Ratio	Frame Size Gear	Motor	Std. Motor Types ◊
61	I	1.1	748	442	28	3012	56	T,S,C,X°,IG
57	I,II,III	2.2	792	1049	31.5	3132	56	T,S,C,X,IG
49	I,II	1.9	917	1086	35.5	3132	56	T,S,C,X,IG
49	III	3+	921	1500	35.5	3252	56	T,S,C,X,IG
45	I,II	1.8	1007	1109	40	3132	56	T,S,C,X,IG
45	III	3+	1016	1541	40	3252	56	T,S,C,X,IG
41	II,III	3+	1115	1580	45	3252	56	T,S,C,X,IG
39	I	1.3	1155	1142	45	3132	56	T,S,C,X,IG
36	I	1.3	1274	1166	50	3132	56	T,S,C,X,IG
35	II,III	3+	1302	1610	50	3252	56	T,S,C,X,IG
31	I,II,III	2.8	1414	1610	56	3253	56	T,S,C,X,IG
27	I,II,III	2.5	1630	1610	63	3253	56	T,S,C,X,IG
26	I,II,III	2.3	1742	1610	71	3253	56	T,S,C,X,IG
22	I,II,III	2.0	1977	1610	80	3253	56	T,S,C,X,IG
20	I,II	1.8	2196	1610	90	3253	56	T,S,C,X,IG
19	III	2.7	2335	2305	90	3363	56	T,S,C,X,IG
18	I,II	1.6	2494	1610	100	3253	56	T,S,C,X,IG
17	III	2.4	2450	2305	100	3363	56	T,S,C,X,IG
16	I,II	1.5	2775	1610	112	3253	56	T,S,C,X,IG
15	III	2.1	2769	2305	112	3363	56	T,S,C,X,IG
14	I	1.3	3122	1610	125	3253	56	T,S,C,X,IG
14	II	1.9	3188	2305	125	3363	56	T,S,C,X,IG
14	III	2.4	3188	2905	125	3373	56	T,S,C,X,IG
12	I	1.1	3659	1610	140	3253	56	T,S,C,X,IG
12	II	1.9	3563	2305	140	3363	56	T,S,C,X,IG
12	III	2.1	3563	2905	140	3373	56	T,S,C,X,IG
11.0	I	1.0	4039	1610	160	3253	56	T,S,C,X,IG
10.8	II	1.5	3943	2305	160	3363	56	T,S,C,X,IG
9.7	I	1.3	4598	2305	180	3363	56	T,S,C,X,IG
9.7	II	1.7	4598	2905	180	3373	56	T,S,C,X,IG
8.7	I	1.2	5089	2305	200	3363	56	T,S,C,X,IG
8.7	II	1.5	5089	2905	200	3373	56	T,S,C,X,IG
7.9	I,II	1.4	5492	2905	224	3374	56	T,S,C,X°,IG
7.1	I	1.2	6138	2905	250	3374	56	T,S,C,X°,IG
6.5	I	1.1	6685	2905	280	3374	56	T,S,C,X°,IG

◊ **Standard Motor Types** (see page 13 for product codes)

T TEFC, three phase, 208-230/460 or 575 volts

S TEFC, single phase, 115/230 volts

C Corro-duty, three phase, 230/460 or 575V

X° Explosion proof, CL1 Grp D, Three phase, 230/460 or 575V

X Explosion proof, CI 1 Grp D, CI 2 grps F&G, three phase, 230/460 or 575V

IG INTELLIGEAR variable speed for 1/230VAC, 3/230V, or 3/460V power supplies



GEARMOTORS

CbN
SERIES **3000**

1 HP

General Specifications: Totally enclosed, 60 hertz, 40°C ambient, continuous duty.

Output RPM	AGMA Class	Service Factor	Output Torque in-lb	OHL lb	Nominal Ratio	Frame Size Gear	Motor	Std. Motor Types ◇
1411	I,II,III	3.1	44	137	1.25	3001	143T	T,S,C,X°,IG
1199	I,II,III	3.1	52	142	1.4	3001	143T	T,S,C,X°,IG
1136	I,II,III	3.1	54	143	1.6	3001	143T	T,S,C,X°,IG
956	I,II,III	3.1	64	148	1.8	3001	143T	T,S,C,X°,IG
893	I,II,III	3.1	69	150	2	3001	143T	T,S,C,X°,IG
799	I,II,III	3.1	77	152	2.24	3001	143T	T,S,C,X°,IG
686	I,II,III	3.1	90	155	2.5	3001	143T	T,S,C,X°,IG
636	I,II,III	3.1	97	156	2.8	3001	143T	T,S,C,X°,IG
540	I,II,III	3.0	114	158	3.15	3001	143T	T,S,C,X°,IG
482	I,II,III	2.7	128	158	3.55	3001	143T	T,S,C,X°,IG
429	I,II,III	2.6	144	157	4	3001	143T	T,S,C,X°,IG
382	I,II,III	2.2	162	156	4.5	3001	143T	T,S,C,X°,IG
338	I	1.0	182	153	5	3001	143T	T,S,C,X°,IG
356	I,II,III	2.6	174	419	5	3101	143T	T,S,C,X,IG
308	I,II,III	2.2	201	437	5.6	3101	143T	T,S,C,X,IG
301	I,II,III	1.0	205	149	5.6	3001	143T	T,S,C,X°,IG
273	I	1.0	226	145	6.3	3001	143T	T,S,C,X°,IG
280	I,II,III	2.0	221	448	6.3	3101	143T	T,S,C,X,IG
242	I	1.0	255	137	7.1	3001	143T	T,S,C,X°,IG
237	I,II,III	2.7	240	428	7.1	3012	143T	T,S,C,X°,IG
214	I,II,III	2.7	282	432	8	3012	143T	T,S,C,X°,IG
204	I,II,III	2.6	297	433	9	3012	143T	T,S,C,X°,IG
172	I,II,III	2.2	353	433	10	3012	143T	T,S,C,X°,IG
160	I,II,III	2.0	378	431	11.2	3012	143T	T,S,C,X°,IG
143	I,II	1.8	423	427	12.5	3012	143T	T,S,C,X°,IG
139	III	2.9	436	794	12.5	3122	143T	T,S,C,X,IG
124	I,II	1.6	492	416	14	3012	143T	T,S,C,X°,IG
124	III	2.6	487	816	14	3122	143T	T,S,C,X,IG
114	I,II	1.5	531	409	16	3012	143T	T,S,C,X°,IG
111	III	2.3	546	839	16	3122	143T	T,S,C,X,IG
97	I	1.3	625	388	18	3012	143T	T,S,C,X°,IG
96	II,III	2.0	632	869	18	3122	143T	T,S,C,X,IG
86	I	1.1	700	368	20	3012	143T	T,S,C,X,IG
87	II	1.8	694	887	20	3122	143T	T,S,C,X,IG
87	III	2.5	878	932	20	3132	143T	T,S,C,X,IG
82	II,III	2.4	739	924	22.4	3132	143T	T,S,C,X,IG
77	I	1.0	787	343	22.4	3012	143T	T,S,C,X°,IG

◇ **Standard Motor Types** (see page 13 for product codes)

T TEFC, three phase, 208-230/460 or 575 volts

S TEFC, single phase, 115/230 volts

C Corro-duty, three phase, 230/460 or 575V

X° Explosion proof, CL1 Grp D, Three phase, 230/460 or 575V

X Explosion proof, Cl 1 Grp D, Cl 2 grps F&G, three phase, 230/460 or 575V

IG INTELLIGEAR variable speed for 1/230VAC, 3/230V, or 3/460V power supplies



GEARMOTORS

1 HP (CONTINUED)

CbN
SERIES 3000

General Specifications: Totally enclosed, 60 hertz, 40°C ambient, continuous duty.

Output RPM	AGMA Class	Service Factor	Output Torque in-lb	OHL lb	Nominal Ratio	Frame Size Gear	Motor	Std. Motor Types ◊
72	II,III	2.1	844	953	25	3132	143T	T,S,C,X,IG
69	I	1.0	795	914	25	3122	143T	T,S,C,X,IG
64	I,II	1.9	942	977	28	3132	143T	T,S,C,X,IG
58	I,II	1.7	1056	1001	31.5	3132	143T	T,S,C,X,IG
58	III	3.8	1047	1398	31.5	3252	143T	T,S,C,X,IG
49	I,II	1.5	1223	1030	35.5	3132	143T	T,S,C,X,IG
49	III	3.3	1228	1456	35.5	3252	143T	T,S,C,X,IG
45	I	1.3	1343	1048	40	3132	143T	T,S,C,X,IG
45	II,III	3.0	1355	1493	40	3252	143T	T,S,C,X,IG
41	II,III	2.7	1486	1526	45	3252	143T	T,S,C,X,IG
39	I	1.0	1540	1072	45	3132	143T	T,S,C,X,IG
36	I	1.0	1699	1089	50	3132	143T	T,S,C,X,IG
35	II,III	2.3	1735	1583	50	3252	143T	T,S,C,X,IG
31	I,II,III	2.1	1886	1610	56	3253	143T	T,S,C,X,IG
27	I,II	1.9	2173	1610	63	3253	143T	T,S,C,X,IG
26	III	2.7	2238	2305	63	3363	143T	T,S,C,X,IG
26	I,II	1.7	2323	1610	71	3253	143T	T,S,C,X,IG
24	III	2.4	2364	2305	71	3363	143T	T,S,C,X,IG
22	I,II	1.5	2636	1610	80	3253	143T	T,S,C,X,IG
22	III	2.2	2653	2305	80	3363	143T	T,S,C,X,IG
20	I,II	1.4	2928	1610	90	3253	143T	T,S,C,X,IG
19	III	2.0	3003	2305	90	3363	143T	T,S,C,X,IG
18	I	1.2	3326	1610	100	3253	143T	T,S,C,X,IG
17	II	1.8	3266	2305	100	3363	143T	T,S,C,X,IG
17	III	2.2	3246	2905	100	3373	143T	T,S,C,X,IG
16	I	1.1	3700	1610	112	3253	143T	T,S,C,X,IG
15	II	1.6	3652	2305	112	3363	143T	T,S,C,X,IG
15	III	2.0	3632	2905	112	3373	143T	T,S,C,X,IG
14	I	1.0	4163	1610	125	3253	143T	T,S,C,X,IG
14	II	1.5	4251	2305	125	3363	143T	T,S,C,X,IG
14	II	1.8	4216	2905	125	3373	143T	T,S,C,X,IG
12.4	I	1.3	4750	2305	140	3363	143T	T,S,C,X,IG
12.4	II	1.6	4720	2905	140	3373	143T	T,S,C,X,IG
10.8	I	1.1	5258	2305	160	3363	143T	T,S,C,X,IG
10.8	II	1.4	5238	2905	160	3373	143T	T,S,C,X,IG
9.7	I	1.0	6130	2305	180	3363	143T	T,S,C,X,IG
9.7	I	1.2	6105	2905	180	3373	143T	T,S,C,X,IG
8.7	I	1.1	6786	2905	200	3373	143T	T,S,C,X,IG
7.9	I	1.0	6786	2905	224	3374	143T	T,S,C,X°,IG

◊ **Standard Motor Types** (see page 13 for product codes)

- T TEFC, three phase, 208-230/460 or 575 volts
- S TEFC, single phase, 115/230 volts
- C Corro-duty, three phase, 230/460 or 575V
- X° Explosion proof, CL1 Grp D, Three phase, 230/460 or 575V
- X Explosion proof, CI 1 Grp D, CI 2 grps F&G, three phase, 230/460 or 575V
- IG INTELLIGEAR variable speed for 1/230VAC, 3/230V, or 3/460V power supplies



GEARMOTORS

CbN
SERIES **3000**

1 1/2 HP

General Specifications: Totally enclosed, 60 hertz, 40°C ambient, continuous duty.

Output RPM	AGMA Class	Service Factor	Output Torque in-lb	OHL lb	Nominal Ratio	Frame Size Gear	Motor	Std. Motor Types ◇
1411	I,II,III	2.0	66	110	1.25	3001	145T	T,S,C,X°,IG
1199	I,II,III	2.0	77	112	1.4	3001	145T	T,S,C,X°,IG
1136	I,II,III	2.0	81	113	1.6	3001	145T	T,S,C,X°,IG
956	I,II,III	2.0	97	114	1.8	3001	145T	T,S,C,X°,IG
893	I,II,III	2.0	104	114	2	3001	145T	T,S,C,X°,IG
799	I,II,III	2.0	116	114	2.24	3001	145T	T,S,C,X°,IG
686	I,II,III	2.0	135	112	2.5	3001	145T	T,S,C,X°,IG
636	I,II,III	2.0	146	111	2.8	3001	145T	T,S,C,X°,IG
540	I,II,III	2.0	171	106	3.15	3001	145T	T,S,C,X°,IG
509	I,II,III	2.4	182	364	3.55	3101	145T	T,S,C,X,IG
482	I,II	1.8	192	101	3.55	3001	145T	T,S,C,X°,IG
445	I,II,III	2.1	208	377	4	3101	145T	T,S,C,X,IG
429	I,II	1.7	216	95	4	3001	145T	T,S,C,X°,IG
401	I,II	1.9	232	389	4.5	3101	145T	T,S,C,X,IG
382	I,II	1.5	243	87	4.5	3001	145T	T,S,C,X°,IG
356	I,II	1.7	260	401	5	3101	145T	T,S,C,X,IG
351	III	4.1	259	596	5	3122	145T	T,S,C,X,IG
310	I,II,III	3+	293	616	5.6	3122	145T	T,S,C,X,IG
308	I,II	1.5	301	417	5.6	3101	145T	T,S,C,X,IG
280	I	1.3	331	426	6.3	3101	145T	T,S,C,X,IG
273	II,III	3+	333	637	6.3	3122	145T	T,S,C,X,IG
238	I,II	1.8	359	347	7.1	3012	145T	T,S,C,X°,IG
238	III	3+	365	652	7.1	3122	145T	T,S,C,X,IG
214	I,II	1.8	423	336	8	3012	145T	T,S,C,X°,IG
211	III	2.9	381	659	8	3122	145T	T,S,C,X,IG
204	I,II	1.7	445	332	9	3012	145T	T,S,C,X°,IG
199	III	2.7	456	689	9	3122	145T	T,S,C,X,IG
172	I,II	1.4	529	312	10	3012	145T	T,S,C,X°,IG
168	III	2.3	541	679	10	3122	145T	T,S,C,X,IG
160	I,II	1.4	567	302	11.2	3012	145T	T,S,C,X°,IG
159	III	2.2	572	726	11.2	3122	145T	T,S,C,X,IG
143	I	1.2	634	282	12.5	3012	145T	T,S,C,X°,IG
140	II	1.9	654	689	12.5	3122	145T	T,S,C,X,IG
140	III	2.5	645	781	12.5	3132	145T	T,S,C,X,IG
123	I	1.0	738	248	14	3012	145T	T,S,C,X°,IG
123	II	1.7	730	717	14	3122	145T	T,S,C,X,IG
123	III	2.3	737	801	14	3132	145T	T,S,C,X,IG
114	I	1.0	796	228	16	3012	145T	T,S,C,X°,IG
111	II	1.5	819	726	16	3122	145T	T,S,C,X,IG
109	III	2.1	831	813	16	3132	145T	T,S,C,X,IG

◇ **Standard Motor Types** (see page 13 for product codes)

- T TEFC, three phase, 208-230/460 or 575 volts
- S TEFC, single phase, 115/230 volts, 145TY
- C Corro-duty, three phase, 230/460 or 575V
- X° Explosion proof, CL1 Grp D, Three phase, 230/460 or 575V
- X Explosion proof, Cl 1 Grp D, Cl 2 grps F&G, three phase, 230/460 or 575V
- IG INTELLIGEAR variable speed for 1/230V, 3/230V, or 3/460V power supplies



GEARMOTORS

CbN
SERIES **3000**

1 1/2 HP (CONTINUED)

General Specifications: Totally enclosed, 60 hertz, 40°C ambient, continuous duty.

Output RPM	AGMA Class	Service Factor	Output Torque in-lb	OHL lb	Nominal Ratio	Frame Size Gear	Frame Size Motor	Std. Motor Types ◊
103	II,III	2.0	882	821	18	3132	145T	T,S,C,X,IG
96	I	1.3	948	747	18	3122	145T	T,S,C,X,IG
88	I	1.2	1041	764	20	3122	145T	T,S,C,X,IG
88	II	1.7	1047	849	20	3132	145T	T,S,C,X,IG
88	III	2.1	1041	1175	20	3242	145T	T,S,C,X,IG
82	I,II	1.6	1108	857	22.4	3132	145T	T,S,C,X,IG
80	III	2.0	1193	1212	22.4	3242	145T	T,S,C,X,IG
72	I,II	1.4	1266	877	25	3132	145T	T,S,C,X,IG
72	III	3.1	1255	1256	25	3252	145T	T,S,C,X,IG
69	I,II	1.7	1317	1238	25	3242	145T	T,S,C,X,IG
65	I	1.3	1413	891	28	3132	145T	T,S,C,X,IG
65	II,III	2.8	1397	1288	28	3252	145T	T,S,C,X,IG
57	I	1.1	1585	905	31.5	3132	145T	T,S,C,X,IG
58	II,III	2.5	1571	1323	31.5	3252	145T	T,S,C,X,IG
49	I	1.0	1834	919	35.5	3132	145T	T,S,C,X,IG
49	II,III	2.2	1842	1368	35.5	3252	145T	T,S,C,X,IG
45	I,II,III	2.0	2033	1396	40	3252	145T	T,S,C,X,IG
41	I,II	1.8	2229	1420	45	3252	145T	T,S,C,X,IG
39	III	2.6	2265	2305	45	3363	145T	T,S,C,X,IG
35	I,II	1.5	2603	1459	50	3252	145T	T,S,C,X,IG
34	III	2.3	2601	2305	50	3363	145T	T,S,C,X,IG
31	I,II	1.4	2828	1492	56	3253	145T	T,S,C,X,IG
30	III	2.1	2929	2305	56	3363	145T	T,S,C,X,IG
27	I	1.2	3260	1511	63	3253	145T	T,S,C,X,IG
26	II	1.8	3181	2305	63	3363	145T	T,S,C,X,IG
26	III	2.2	3417	2905	63	3373	145T	T,S,C,X,IG
26	I	1.2	3484	1534	71	3253	145T	T,S,C,X,IG
24	II	1.6	3704	2305	71	3363	145T	T,S,C,X,IG
24	III	2.0	3699	2905	71	3373	145T	T,S,C,X,IG
22	I	1.0	3954	1555	80	3253	145T	T,S,C,X,IG
22	II	1.5	3979	2305	80	3363	145T	T,S,C,X,IG
22	II	1.9	4039	2905	80	3373	145T	T,S,C,X,IG
19	I	1.3	4504	2305	90	3363	145T	T,S,C,X,IG
19	II	1.7	4576	2905	90	3373	145T	T,S,C,X,IG
17	I	1.2	5136	2305	100	3363	145T	T,S,C,X,IG
17	II	1.5	5116	2905	100	3373	145T	T,S,C,X,IG
15	I	1.0	5813	2305	112	3363	145T	T,S,C,X,IG
15	I	1.3	5798	2905	112	3373	145T	T,S,C,X,IG
14	I	1.2	6324	2905	125	3373	143T	T,S,C,X,IG
12	I	1.1	7125	2905	140	3373	143T	T,S,C,X,IG

◊ **Standard Motor Types** (see page 13 for product codes)

T TEFC, three phase, 208-230/460 or 575 volts

S TEFC, single phase, 115/230 volts, 145TY

C Corro-duty, three phase, 230/460 or 575V

X° Explosion proof, CL1 Grp D, Three phase, 230/460 or 575V

X Explosion proof, CI 1 Grp D, CI 2 grps F&G, three phase, 230/460 or 575V

IG INTELLIGEAR variable speed for 1/230V, 3/230V, or 3/460V power supplies



GEARMOTORS

CbN SERIES 3000

2 HP

General Specifications: Totally enclosed, 60 hertz, 40°C ambient, continuous duty.

Output RPM	AGMA Class	Service Factor	Output Torque in-lb	OHL lb	Nominal Ratio	Frame Size Gear	Motor	Std. Motor Types ◊
1434	I,II,III	3+	86	260	1.25	3101	145T	T,S,C,X,IG
1411	I,II,III	1.5	88	84	1.25	3001	145T	T,S,C,X°,IG
1268	I,II,III	3+	97	270	1.4	3101	145T	T,S,C,X,IG
1199	I,II	1.5	103	83	1.4	3001	145T	T,S,C,X°,IG
1136	I,II	1.5	109	83	1.6	3001	145T	T,S,C,X°,IG
1122	III	3+	110	280	1.6	3101	145T	T,S,C,X,IG
994	II,III	3.0	124	291	1.8	3101	145T	T,S,C,X,IG
956	I,II	1.5	129	80	1.8	3001	145T	T,S,C,X°,IG
893	I,II	1.5	138	79	2	3001	145T	T,S,C,X°,IG
875	III	2.8	141	302	2	3101	145T	T,S,C,X,IG
799	I,II	1.5	155	75	2.24	3001	145T	T,S,C,X°,IG
764	III	2.7	161	313	2.24	3101	145T	T,S,C,X,IG
686	I,II	1.5	180	69	2.5	3001	145T	T,S,C,X°,IG
678	III	2.4	182	324	2.5	3101	145T	T,S,C,X,IG
637	I,II	1.5	194	65	2.8	3001	145T	T,S,C,X°,IG
637	III	2.3	193	330	2.8	3101	145T	T,S,C,X,IG
540	I,II	1.5	228	54	3.15	3001	145T	T,S,C,X°,IG
538	II	1.9	229	345	3.15	3101	145T	T,S,C,X,IG
510	I,II	1.8	243	351	3.55	3101	145T	T,S,C,X,IG
510	III	2.9	245	456	3.55	3201	145T	T,S,C,X,IG
482	I,II	1.4	256	45	3.55	3001	145T	T,S,C,X°,IG
446	I,II	1.6	277	363	4	3101	145T	T,S,C,X,IG
446	III	3+	271	543	4	3122	145T	T,S,C,X,IG
429	I	1.3	288	33	4	3001	145T	T,S,C,X°,IG
401	I,II	1.4	310	373	4.5	3101	145T	T,S,C,X,IG
395	III	3+	306	561	4.5	3122	145T	T,S,C,X,IG
356	I	1.3	347	383	5	3101	145T	T,S,C,X,IG
351	II,III	3.1	345	578	5	3122	145T	T,S,C,X,IG
309	I	1.1	402	397	5.6	3101	145T	T,S,C,X,IG
309	II,III	3.0	391	595	5.6	3122	145T	T,S,C,X,IG
280	I	1.0	441	405	6.3	3101	145T	T,S,C,X,IG
273	II,III	2.8	444	613	6.3	3122	145T	T,S,C,X,IG
238	I	1.3	479	265	7.1	3012	145T	T,S,C,X°,IG
238	II,III	2.5	507	632	7.1	3122	145T	T,S,C,X,IG
214	I	1.3	564	240	8	3012	145T	T,S,C,X°,IG
211	II,III	2.2	573	648	8	3122	145T	T,S,C,X,IG
204	I	1.3	594	230	9	3012	145T	T,S,C,X°,IG
199	II,III	2.1	608	656	9	3122	145T	T,S,C,X,IG
181	I,II,III	2.2	668	691	10	3132	145T	T,S,C,X,IG
172	I	1.1	705	192	10	3012	145T	T,S,C,X°,IG

◊ **Standard Motor Types** (see page 13 for product codes)

- T TEFC, three phase, 208-230/460 or 575 volts
- S TEFC, single phase, 115/230 volts, 145TY
- C Corro-duty, three phase, 230/460 or 575V
- X° Explosion proof, CL1 Grp D, Three phase, 230/460 or 575V
- X Explosion proof, Cl 1 Grp D, Cl 2 grps F&G, three phase, 230/460 or 575V
- IG INTELLIGEAR variable speed for 1/230V, 3/230V, or 3/460V power supplies. Motor frame is 145TY.



GEARMOTORS

2 HP (CONTINUED)

CbN
SERIES **3000**

General Specifications: Totally enclosed, 60 hertz, 40°C ambient, continuous duty.

Output RPM	AGMA Class	Service Factor	Output Torque in-lb	OHL lb	Nominal Ratio	Frame Size Gear	Motor	Std. Motor Types ◊
168	II	1.7	721	678	10	3122	145T	T,S,C,X,IG
160	I	1.0	755	173	11.2	3012	145T	T,S,C,X°,IG
160	II	1.6	763	685	11.2	3122	145T	T,S,C,X,IG
160	III	2.0	756	709	11.2	3132	145T	T,S,C,X,IG
141	I,II	1.9	859	727	12.5	3132	145T	T,S,C,X,IG
139	I,II	1.4	872	700	12.5	3122	145T	T,S,C,X,IG
128	II,II	2.3	973	1035	14	3242	145T	T,S,C,X,IG
124	I	1.3	973	711	14	3122	145T	T,S,C,X,IG
123	II	1.7	982	745	14	3132	145T	T,S,C,X,IG
111	I	1.1	1091	722	16	3122	145T	T,S,C,X,IG
114	II,III	2.1	1091	1062	16	3242	145T	T,S,C,X,IG
109	I,II	1.6	1108	760	16	3132	145T	T,S,C,X,IG
103	I,II	1.5	1176	767	18	3132	145T	T,S,C,X,IG
97	II	1.8	1264	1096	18	3242	145T	T,S,C,X,IG
96	I	1.0	1264	733	18	3122	145T	T,S,C,X,IG
91	III	2.8	1326	1139	20	3252	145T	T,S,C,X,IG
88	I	1.3	1397	785	20	3132	145T	T,S,C,X,IG
88	II	1.6	1387	1116	20	3242	145T	T,S,C,X,IG
82	I	1.2	1477	790	22.4	3132	145T	T,S,C,X,IG
82	II,III	2.6	1473	1166	22.4	3252	145T	T,S,C,X,IG
80	I,II	1.5	1591	1145	22.4	3242	145T	T,S,C,X,IG
72	I	1.0	1688	800	25	3132	145T	T,S,C,X,IG
72	II,III	2.4	1674	1197	25	3252	145T	T,S,C,X,IG
69	I	1.3	1756	1165	25	3242	145T	T,S,C,X,IG
65	I,II,III	2.1	1862	1222	28	3252	145T	T,S,C,X,IG
58	I,II	1.9	2095	1248	31.5	3252	145T	T,S,C,X,IG
54	III	2.7	2156	2305	31.5	3363	145T	T,S,C,X,IG
49	I,II	1.6	2455	1281	35.5	3252	145T	T,S,C,X,IG
47	III	2.4	2382	2305	35.5	3363	145T	T,S,C,X,IG
45	I,II	1.5	2710	1299	40	3252	145T	T,S,C,X,IG
43	III	2.2	2733	2305	40	3363	145T	T,S,C,X,IG
41	I	1.3	2972	1314	45	3252	145T	T,S,C,X,IG
39	II,III	2.0	3020	2305	45	3363	145T	T,S,C,X,IG
36	III	2.1	3366	2905	50	3372	145T	T,S,C,X,IG
35	I	1.2	3471	1335	50	3252	145T	T,S,C,X,IG
34	II	1.7	3468	2305	50	3363	145T	T,S,C,X,IG
31	I	1.1	3771	1357	56	3253	145T	T,S,C,X,IG
30	II	1.6	3905	2305	56	3363	145T	T,S,C,X,IG
30	II	1.9	3889	2905	56	3373	145T	T,S,C,X,IG

◊ **Standard Motor Types** (see page 13 for product codes)

T TEFC, three phase, 208-230/460 or 575 volts

S TEFC, single phase, 115/230 volts, 145TY

C Corro-duty, three phase, 230/460 or 575V

X° Explosion proof, CL1 Grp D, Three phase, 230/460 or 575V

X Explosion proof, CI 1 Grp D, CI 2 grps F&G, three phase, 230/460 or 575V

IG INTELLIGEAR variable speed for 1/230V, 3/230V, or 3/460V power supplies. Motor frame is 145TY.



GEARMOTORS

2 HP (CONTINUED)

CbN
SERIES **3000**

General Specifications: Totally enclosed, 60 hertz, 40°C ambient, continuous duty.

Output RPM	AGMA Class	Service Factor	Output Torque in-lb	OHL lb	Nominal Ratio	Frame Size Gear	Motor	Std. Motor Types ◊
26	I,II	1.4	4242	2305	63	3363	145T	T,S,C,X,IG
26	II	1.7	4215	2905	63	3373	145T	T,S,C,X,IG
24	I	1.2	4728	2305	71	3363	145T	T,S,C,X,IG
24	I,II	1.5	4702	2905	71	3373	145T	T,S,C,X,IG
22	I	1.1	5306	2305	80	3363	145T	T,S,C,X,IG
22	II	1.4	5295	2905	80	3373	145T	T,S,C,X,IG
19	I	1.0	6005	2305	90	3363	145T	T,S,C,X,IG
19	I	1.3	6101	2905	90	3373	145T	T,S,C,X,IG
17	I	1.1	6847	2905	100	3373	145T	T,S,C,X,IG
15	I	1.0	7751	2905	112	3373	145T	T,S,C,X,IG

◊ **Standard Motor Types** (see page 13 for product codes)

T TEFC, three phase, 208-230/460 or 575V

S TEFC, single phase, 115/230V

C Corro-duty, three phase, 230/460 or 575V

X° Explosionproof, CL1 Grp D, three phase, 230/460 or 575V

X Explosionproof, CI 1 Grp D, CI 2 Grps F&G, three phase, 230/460 or 575V

IG INTELLIGEAR variable speed for 1/230V, 3/230V, or 3/460V power supplies, Motor frame is 145TY



GEARMOTORS

CbN
SERIES **3000**

2 1/2 HP

General Specifications: Totally enclosed, 60 hertz, 40°C ambient, continuous duty.

Output RPM	AGMA Class	Service Factor	Output Torque in-lb	OHL lb	Nominal Ratio	Frame Size Gear	Frame Size Motor	Std. Motor Types ◊
1434	I,II,III	2.7	108	254	1.25	3101	145TY	T,C
1268	I,II,III	2.5	122	263	1.4	3101	145TY	T,C
1122	I,II,III	2.5	137	273	1.6	3101	145TY	T,C
994	I,II,III	2.4	155	283	1.8	3101	145TY	T,C
875	I,II,III	2.3	176	293	2	3101	145TY	T,C
764	I,II,III	2.1	202	304	2.24	3101	145TY	T,C
678	I,II	1.9	228	314	2.5	3101	145TY	T,C
639	I,II	1.8	241	319	2.8	3101	145TY	T,C
632	III	2.9	240	415	2.8	3201	145TY	T,C
566	III	2.6	272	429	3.15	3201	145TY	T,C
538	I,II	1.5	287	333	3.15	3101	145TY	T,C
510	I,II	1.5	303	337	3.55	3101	145TY	T,C
510	III	2.3	303	440	3.55	3201	145TY	T,C
446	I	1.3	347	348	4	3101	145TY	T,C
446	II,III	2.8	338	528	4	3122	145TY	T,C
401	I	1.1	387	357	4.5	3101	145TY	T,C
395	II,III	2.5	383	544	4.5	3122	145TY	T,C
356	I	1.0	434	366	5	3101	145TY	T,C
351	II,III	2.5	432	559	5	3122	145TY	T,C
310	I,II,III	2.4	488	574	5.6	3122	145TY	T,C
273	I,II,III	2.3	555	590	6.3	3122	145TY	T,C
253	I	1.2	599	183	7.1	3012	145TY	T,C
238	II,III	2.0	634	605	7.1	3122	145TY	T,C
231	III	2.1	655	630	8	3132	145TY	T,C
211	I,II	1.7	716	618	8	3122	145TY	T,C
204	I,II	1.9	741	646	9	3132	145TY	T,C
204	III	3.0	759	897	9	3242	145TY	T,C
199	I,II	1.6	759	624	9	3122	145TY	T,C
181	I,II	1.8	836	661	10	3132	145TY	T,C
180	III	2.6	902	934	10	3242	145TY	T,C
168	II	1.4	902	639	10	3122	145TY	T,C
159	I	1.3	954	644	11.2	2133	145TY	T,C
160	I,II	1.6	945	675	11.2	3132	145TY	T,C
143	II,III	2.1	954	945	12.5	3242	145TY	T,C
140	I	1.1	1090	653	12.5	3122	145TY	T,C
140	I,II	1.5	1074	688	12.5	3132	145TY	T,C

◊ **Standard Motor Types** (see page 13 for product codes)

T TEFC, three phase, 208-230/460 or 575 volts

C Corro-duty, three phase, 230/460 or 575V



GEARMOTORS

2 1/2 HP (CONTINUED)

CbN
SERIES **3000**

General Specifications: Totally enclosed, 60 hertz, 40°C ambient, continuous duty.

Output RPM	AGMA Class	Service Factor	Output Torque in-lb	OHL lb	Nominal Ratio	Frame Size Gear	Motor	Std. Motor Types ◊
128	I,II	1.9	1090	973	14	3242	145TY	T,C
124	I,II	1.4	1228	701	14	3132	145TY	T,C
114	I,II	1.7	1217	995	16	3242	145TY	T,C
110	I	1.3	1385	710	16	3132	145TY	T,C
110	II,III	2.6	1452	1091	16	3252	145TY	T,C
103	I	1.2	1470	714	18	3132	145TY	T,C
97	II	1.4	1364	1017	18	3242	145TY	T,C
91	III	2.2	1658	1092	20	3252	145TY	T,C
88	I	1.0	1746	722	20	3132	145TY	T,C
88	I	1.3	1580	1043	20	3242	145TY	T,C
82	II,III	2.1	1842	1113	22.4	3252	145TY	T,C
80	I	1.2	1734	1058	22.4	3242	145TY	T,C
72	II	1.9	2092	1137	25	3252	145TY	T,C
70	I,II,III	2.5	2120	2305	25	3363	145TY	T,C
69	I	1.0	1989	1079	25	3242	145TY	T,C
65	I,II	1.7	2328	1155	28	3252	145TY	T,C
63	I,II,III	3.0	2445	2305	28	3372	145TY	T,C
58	I,II	1.5	2618	1173	31.5	3252	145TY	T,C
54	III	2.2	2695	2305	31.5	3263	145TY	T,C
50	I	1.3	3069	1193	35.5	3252	145TY	T,C
50	II,III	2.4	2965	2905	35.5	3372	145TY	T,C
47	I,II	1.9	3218	2305	35.5	3363	145TY	T,C
45	I	1.2	3388	1202	40	3252	145TY	T,C
44	II	1.7	3416	2305	40	3363	145TY	T,C
44	III	2.1	3402	2905	40	3372	145TY	T,C
41	I	1.1	3715	1208	45	3252	145TY	T,C
40	II	1.9	3801	2905	45	3372	145TY	T,C
39	I,II	1.6	3775	2305	45	3363	145TY	T,C
36	I,II	1.7	4207	2905	50	3372	145TY	T,C
34	I,II	1.4	4335	2305	50	3363	145TY	T,C
30	I	1.3	4881	2305	56	3363	145TY	T,C
30	II	1.4	4862	2905	56	3373	145TY	T,C
26	I	1.1	5817	2305	63	3363	145TY	T,C
26	I	1.3	5795	2905	63	3373	145TY	T,C
24	I	1.2	6171	2905	71	3373	145TY	T,C
22	I	1.1	6732	2905	80	3373	145TY	T,C
19	I	1.0	7601	2905	90	3373	145TY	T,C

◊ **Standard Motor Types** (see page 13 for product codes)

T TEFC, three phase, 208-230/460 or 575 volts

C Corro-duty, three phase, 230/460 or 575V



GEARMOTORS

CbN SERIES 3000

3 HP

General Specifications: Totally enclosed, 60 hertz, 40°C ambient, continuous duty.

Output RPM	AGMA Class	Service Factor	Output Torque in-lb	OHL lb	Nominal Ratio	Frame Size Gear	Motor	Std. Motor Types ◊
1434	I,II,III	2.3	129	248	1.25	3101	182T	T,S,C,X,IG
1268	I,II,III	2.1	146	257	1.4	3101	182T	T,S,C,X,IG
1122	I,II,III	2.1	165	265	1.6	3101	182T	T,S,C,X,IG
994	I,II,III	2.0	186	275	1.8	3101	182T	T,S,C,X,IG
902	I,II,III	3+	205	370	2	3201	182T	T,S,C,X,IG
875	I,II	1.9	212	284	2	3101	182T	T,S,C,X,IG
792	I,II,III	3.0	234	382	2.24	3201	182T	T,S,C,X,IG
764	I,II	1.8	242	294	2.24	3101	182T	T,S,C,X,IG
686	I,II,III	2.6	270	397	2.5	3201	182T	T,S,C,X,IG
678	I,II	1.6	273	303	2.5	3101	182T	T,S,C,X,IG
639	I,II	1.5	290	308	2.8	3101	182T	T,S,C,X,IG
632	III	2.5	288	403	2.8	3201	182T	T,S,C,X,IG
566	I,II,III	2.2	327	415	3.15	3201	182T	T,S,C,X,IG
538	I	1.3	344	320	3.15	3101	182T	T,S,C,X,IG
510	I	1.2	364	324	3.55	3101	182T	T,S,C,X,IG
510	II,III	2.0	363	425	3.55	3201	182T	T,S,C,X,IG
450	II	1.7	412	437	4	3201	182T	T,S,C,X,IG
446	I	1.1	416	334	4	3101	182T	T,S,C,X,IG
446	III	2.3	406	514	4	3122	182T	T,S,C,X,IG
404	II	1.5	459	447	4.5	3201	182T	T,S,C,X,IG
401	I	1.0	464	341	4.5	3101	182T	T,S,C,X,IG
395	I,II,III	2.1	459	528	4.5	3122	182T	T,S,C,X,IG
359	I,II	1.4	516	457	5	3201	182T	T,S,C,X,IG
351	III	2.0	518	541	5	3122	182T	T,S,C,X,IG
318	III	3+	586	786	5.6	3242	182T	T,S,C,X,IG
310	II,III	2.0	586	553	5.6	3122	182T	T,S,C,X,IG
306	I	1.2	605	470	5.6	3201	182T	T,S,C,X,IG
287	III	3+	666	811	6.3	3242	182T	T,S,C,X,IG
273	I,II	1.9	666	566	6.3	3122	182T	T,S,C,X,IG
251	I,II,III	3+	761	837	7.1	3242	182T	T,S,C,X,IG
238	I,II	1.6	761	577	7.1	3122	182T	T,S,C,X,IG
231	I,II	1.7	786	606	8	3132	182T	T,S,C,X,IG
218	III	2.7	859	860	8	3242	182T	T,S,C,X,IG
211	I,II	1.5	859	587	8	3122	182T	T,S,C,X,IG
199	I,II	1.4	911	591	9	3122	182T	T,S,C,X,IG
204	II	1.6	889	619	9	3132	182T	T,S,C,X,IG
204	III	2.5	911	872	9	3242	182T	T,S,C,X,IG
181	I,II	1.5	1003	630	10	3132	182T	T,S,C,X,IG
180	III	2.2	1082	903	10	3242	182T	T,S,C,X,IG
168	I	1.2	1082	601	10	3122	182T	T,S,C,X,IG

◊ **Standard Motor Types** (see page 13 for product codes)

- T TEFC, three phase, 208-230/460 or 575 volts
- S TEFC, single phase, 230 volts, 184T frame
- C Corro-duty, three phase, 230/460 or 575V
- X Explosion proof, CI 1 Grp D, CI 2 grps F&G, three phase, 230/460 or 575V
- IG INTELLIGEAR variable speed for 3/460V power supplies



GEARMOTORS

3 HP (CONTINUED)

CbN
SERIES 3000

General Specifications: Totally enclosed, 60 hertz, 40°C ambient, continuous duty.

Output RPM	AGMA Class	Service Factor	Output Torque in-lb	OHL lb	Nominal Ratio	Frame Size Gear	Motor	Std. Motor Types \diamond
161	I	1.1	1145	603	11.2	3122	182T	T,S,C,X,IG
161	II	1.4	1134	614	11.2	3132	182T	T,S,C,X,IG
161	III	2.0	1145	913	11.2	3242	182T	T,S,C,X,IG
142	I	1.2	1289	649	12.5	3132	182T	T,S,C,X,IG
142	II	1.7	1308	936	12.5	3242	182T	T,S,C,X,IG
142	III	2.5	1249	959	12.5	3252	182T	T,S,C,X,IG
128	II	1.6	1460	954	14	3242	182T	T,S,C,X,IG
128	III	2.3	1423	985	14	3252	182T	T,S,C,X,IG
123	I	1.1	1473	656	14	3132	182T	T,S,C,X,IG
114	II	1.4	1637	971	16	3242	182T	T,S,C,X,IG
110	I	1.1	1662	660	16	3132	182T	T,S,C,X,IG
110	III	2.1	1641	1012	16	3252	182T	T,S,C,X,IG
103	I	1.0	1764	660	18	3132	182T	T,S,C,X,IG
103	III	2.0	1753	1023	18	3252	182T	T,S,C,X,IG
97	I	1.2	1898	990	18	3242	182T	T,S,C,X,IG
91	I,II	1.9	1990	1044	20	3252	182T	T,S,C,X,IG
88	I	1.1	2081	1000	20	3242	182T	T,S,C,X,IG
88	III	3+	2037	2620	20	3372	182T	T,S,C,X,IG
81	I	1.0	2384	1012	22.4	3242	182T	T,S,C,X,IG
81	II	1.7	2210	1060	22.4	3252	182T	T,S,C,X,IG
81	III	3+	2270	2699	22.4	3372	182T	T,S,C,X,IG
72	I,II	1.6	2510	1077	25	3252	182T	T,S,C,X,IG
70	III	2.1	2543	2305	25	3372	182T	T,S,C,X,IG
65	I,II	1.4	2793	1089	28	3252	182T	T,S,C,X,IG
63	III	2.5	2548	2784	28	3372	182T	T,S,C,X,IG
58	I	1.3	3142	1098	31.5	3252	182T	T,S,C,X,IG
58	II,III	2.3	2884	2878	31.5	3372	182T	T,S,C,X,IG
54	I,II	1.8	3234	2305	31.5	3363	182T	T,S,C,X,IG
51	III	2.0	3137	2905	35.5	3372	182T	T,S,C,X,IG
49	I	1.1	3683	1105	35.5	3252	182T	T,S,C,X,IG
47	I,II	1.6	3781	2305	35.5	3363	182T	T,S,C,X,IG
45	I	1.0	4066	1105	40	3252	182T	T,S,C,X,IG
44	I,II	1.4	4099	2305	40	3363	182T	T,S,C,X,IG
44	I,II	1.7	3545	2905	40	3372	182T	T,S,C,X,IG
39	I	1.3	4557	2305	45	3363	182T	T,S,C,X,IG
39	II	1.6	4531	2905	45	3372	182T	T,S,C,X,IG
35	I	1.2	5202	2305	50	3363	182T	T,S,C,X,IG
35	II	1.4	4961	2905	50	3372	182T	T,S,C,X,IG
30	I	1.0	5858	2305	56	3363	182T	T,S,C,X,IG
30	I	1.3	5836	2905	56	3373	182T	T,S,C,X,IG
26	I	1.1	6835	2905	63	3373	182T	T,S,C,X,IG
24	I	1.0	7405	2305	71	3373	182T	T,S,C,X,IG

\diamond Standard Motor Types (see page 13 for product codes)

- T TEFC, three phase, 208-230/460 or 575 volts
- S TEFC, single phase, 230 volts, 184T frame
- C Corro-duty, three phase, 230/460 or 575V
- X Explosion proof, CI 1 Grp D, CI 2 grps F&G, three phase, 230/460 or 575V
- IG INTELLIGEAR variable speed for 3/460V power supplies



GEARMOTORS

CbN3000 SERIES

5 HP

General Specifications: Totally enclosed, 60 hertz, 40°C ambient, continuous duty.

Output RPM	AGMA Class	Service Factor	Output Torque in-lb	OHL lb	Nominal Ratio	Frame Size Gear	Motor	Std. Motor Types ◊
1434	I,II	1.4	215	222	1.25	3101	184T	T,S,C,X,IG
1423	III	2.4	217	298	1.25	3201	184T	T,S,C,X,IG
1268	I	1.3	243	229	1.4	3101	184T	T,S,C,X,IG
1207	II,III	2.2	256	311	1.4	3201	184T	T,S,C,X,IG
1129	II,III	2.3	273	316	1.6	3201	184T	T,S,C,X,IG
1122	I	1.2	275	236	1.6	3101	184T	T,S,C,X,IG
1000	II,III	2.1	309	324	1.8	3201	184T	T,S,C,X,IG
994	I	1.2	311	229	1.8	3101	184T	T,S,C,X,IG
902	II,III	2.1	342	332	2	3201	184T	T,S,C,X,IG
875	I	1.1	353	217	2	3101	184T	T,S,C,X,IG
792	II	1.8	390	340	2.24	3201	184T	T,S,C,X,IG
778	III	2.7	397	848	2.24	3301	184T	T,S,C,X,IG
764	I	1.1	403	200	2.24	3101	184T	T,S,C,X,IG
686	II	1.6	449	349	2.5	3201	184T	T,S,C,X,IG
678	I	1.0	455	179	2.5	3101	184T	T,S,C,X,IG
678	III	2.8	456	883	2.5	3301	184T	T,S,C,X,IG
632	I,II	1.5	480	353	2.8	3201	184T	T,S,C,X,IG
601	III	2.4	513	913	2.8	3301	184T	T,S,C,X,IG
566	I	1.3	545	360	3.15	3201	184T	T,S,C,X,IG
554	II,III	2.0	558	934	3.15	3301	184T	T,S,C,X,IG
510	I	1.2	605	365	3.55	3201	184T	T,S,C,X,IG
497	II,III	2.0	621	962	3.55	3201	184T	T,S,C,X,IG
450	II	1.4	676	455	4	3122	184T	T,S,C,X,IG
450	I	1.0	687	370	4	3201	184T	T,S,C,X,IG
450	III	3+	676	669	4	3242	184T	T,S,C,X,IG
395	I	1.3	766	462	4.5	3122	184T	T,S,C,X,IG
383	II,III	2.8	790	687	4.5	3242	184T	T,S,C,X,IG
359	II,III	2.6	844	704	5	3242	184T	T,S,C,X,IG
351	I	1.2	863	466	5	3122	184T	T,S,C,X,IG
318	II,III	2.3	953	720	5.6	3242	184T	T,S,C,X,IG
310	I	1.2	977	469	5.6	3122	184T	T,S,C,X,IG
287	II,III	2.1	1054	737	6.3	3242	184T	T,S,C,X,IG
273	I	1.1	1110	470	6.3	3122	184T	T,S,C,X,IG
251	II	1.8	1203	752	7.1	3242	184T	T,S,C,X,IG
247	III	2.9	1225	1893	7.1	3362	184T	T,S,C,X,IG
238	I	1.0	1269	468	7.1	3122	184T	T,S,C,X,IG

- ◊ **Standard Motor Types** (see page 13 for product codes)
- T TEFC, three phase, 208-230/460 or 575 volts
 - S TEFC, single phase, 230 volts
 - C Corro-duty, three phase, 230/460 or 575V
 - X Explosion proof, CI 1 Grp D, CI 2 grps F&G, three phase, 230/460 or 575V
 - IG INTELLIGEAR variable speed for 3/460V power supplies



GEARMOTORS

5 HP (CONTINUED)

CbN
SERIES 3000

General Specifications: Totally enclosed, 60 hertz, 40°C ambient, continuous duty.

Output RPM	AGMA Class	Service Factor	Output Torque in-lb	OHL lb	Nominal Ratio	Frame Size Gear	Motor	Std. Motor Types ◇
231	I	1.0	1309	511	8	3132	184T	T,S,C,X,IG
229	III	2.1	1320	789	8	3252	184T	T,S,C,X,IG
218	II	1.6	1431	764	8	3242	184T	T,S,C,X,IG
204	I,II	1.5	1519	770	9	3242	184T	T,S,C,X,IG
194	II	1.9	1559	810	9	3252	184T	T,S,C,X,IG
191	III	2.3	1584	2031	9	3362	184T	T,S,C,X,IG
181	I	1.3	1804	782	10	3242	184T	T,S,C,X,IG
181	II	1.8	1663	818	10	3252	184T	T,S,C,X,IG
176	III	2.1	1721	2076	10	3362	184T	T,S,C,X,IG
162	I	1.2	1908	785	11.2	3242	184T	T,S,C,X,IG
161	II	1.6	1880	831	11.2	3252	184T	T,S,C,X,IG
158	II	1.9	1918	2136	11.2	3362	184T	T,S,C,X,IG
158	III	3.3	1906	2137	11.2	3372	184T	T,S,C,X,IG
145	I	1.5	2081	840	12.5	3252	184T	T,S,C,X,IG
143	I	1.0	2180	790	12.5	3242	184T	T,S,C,X,IG
141	II	1.7	2152	2200	12.5	3362	184T	T,S,C,X,IG
138	III	3.1	2187	2216	12.5	3372	184T	T,S,C,X,IG
128	I,II	1.4	2372	849	14	3252	184T	T,S,C,X,IG
125	III	2.8	2417	2273	14	3372	184T	T,S,C,X,IG
124	I,II	1.5	2436	2268	14	3362	184T	T,S,C,X,IG
114	II	1.4	2650	2315	16	3362	184T	T,S,C,X,IG
111	I	1.3	2734	855	16	3252	184T	T,S,C,X,IG
109	III	2.5	2775	2354	16	3372	184T	T,S,C,X,IG
104	I	1.2	2922	856	18	3252	184T	T,S,C,X,IG
97	II,III	2.3	3125	2422	18	3372	184T	T,S,C,X,IG
91	I	1.1	3316	855	20	3252	184T	T,S,C,X,IG
89	II,III	2.1	3395	2470	20	3372	184T	T,S,C,X,IG
82	I	1.0	3683	850	22.4	3252	184T	T,S,C,X,IG
80	II	1.9	3783	2532	22.4	3372	184T	T,S,C,X,IG
70	I	1.2	4239	2305	25	3362	184T	T,S,C,X,IG
70	II	1.7	4246	2596	25	3372	184T	T,S,C,X,IG
63	I,II	1.5	4806	2663	28	3372	184T	T,S,C,X,IG
58	II	1.4	5228	2708	31.5	3372	184T	T,S,C,X,IG
54	I	1.1	5480	2305	31.5	3363	184T	T,S,C,X,IG
51	I	1.2	5908	2704	35.5	3372	184T	T,S,C,X,IG
44	I	1.0	6804	2749	40	3372	184T	T,S,C,X,IG

◇ **Standard Motor Types** (see page 13 for product codes)
 T TEFC, three phase, 208-230/460 or 575 volts
 S TEFC, single phase, 230 volts
 C Corro-duty, three phase, 230/460 or 575V
 X Explosion proof, CI 1 Grp D, CI 2 grps F&G, three phase, 230/460 or 575V
 IG INTELLIGEAR variable speed for 3/460V power supplies



GEARMOTORS

CbN
SERIES 3000

7 1/2 HP

General Specifications: Totally enclosed, 60 hertz, 40°C ambient, continuous duty.

Output RPM	AGMA Class	Service Factor	Output Torque in-lb	OHL lb	Nominal Ratio	Frame Size Gear	Motor	Std. Motor Types ◊
1423	I,II	1.6	325	264	1.25	3201	213T	T,C,X
1389	I,II	1.9	334	688	1.25	3301	213T	T,C,X
1207	I,II	1.5	384	272	1.4	3201	213T	T,C,X
1199	II	1.8	386	717	1.4	3301	213T	T,C,X
1129	I,II	1.5	410	275	1.6	3201	213T	T,C,X
1087	I,II	1.8	425	738	1.6	3301	213T	T,C,X
1000	I,II	1.4	463	280	1.8	3201	213T	T,C,X
989	I,II	1.9	470	759	1.8	3301	213T	T,C,X
902	I,II	1.4	513	284	2	3201	213T	T,C,X
836	I,II	1.9	539	778	2	3301	213T	T,C,X
792	I	1.2	585	288	2.24	3201	213T	T,C,X
778	II	1.8	596	788	2.24	3301	213T	T,C,X
686	I	1.1	674	291	2.5	3201	213T	T,C,X
678	II	1.9	684	800	2.5	3301	213T	T,C,X
601	I,II	1.6	770	807	2.8	3301	213T	T,C,X
554	I	1.3	836	809	3.15	3301	213T	T,C,X
497	I	1.3	908	258	3.55	3301	213T	T,C,X
452	I,II,III	2.1	1015	612	4	3242	213T	T,C,X
383	II	1.9	1148	623	4.5	3242	213T	T,C,X
391	I	1.1	932	810	4.5	3301	213T	T,C,X
381	III	3.0	1190	1621	4.5	3362	213T	T,C,X
359	II	1.7	1295	631	5	3242	213T	T,C,X
359	I	1.0	1264	806	5	3301	213T	T,C,X
346	III	2.8	1312	1665	5	3362	213T	T,C,X
318	I,II	1.5	1465	639	5.6	3242	213T	T,C,X
313	III	2.5	1449	1709	5.6	3362	213T	T,C,X
287	I,II	1.4	1665	644	6.3	3242	213T	T,C,X
273	III	2.2	1663	1771	6.3	3362	213T	T,C,X
251	I	1.2	1903	646	7.1	3242	213T	T,C,X
247	II,III	2.0	1838	1816	7.1	3362	213T	T,C,X
229	II	1.4	1980	695	8	3252	213T	T,C,X
218	I	1.1	2147	644	8	3242	213T	T,C,X
223	III	2.8	2035	1871	8	3372	213T	T,C,X
215	II	1.7	2110	1879	8	3362	213T	T,C,X
204	I	1.0	2278	643	9	3242	213T	T,C,X

◊ **Standard Motor Types** (see page 13 for product codes)

T TEFC, three phase, 208-230/460 or 575 volts

C Corro-duty, three phase, 230/460 or 575V

X Explosion proof, CI 1 Grp D, CI 2 grps F&G, three phase, 230/460 or 575V



GEARMOTORS

CbN SERIES 3000

7 1/2 HP (CONTINUED)

General Specifications: Totally enclosed, 60 hertz, 40°C ambient, continuous duty.

Output RPM	AGMA Class	Service Factor	Output Torque in-lb	OHL lb	Nominal Ratio	Frame Size Gear	Frame Size Motor	Std. Motor Types \diamond
194	I	1.2	2339	699	9	3252	213T	T,C,X
192	II	1.5	2376	1932	9	3362	213T	T,C,X
192	III	2.6	2348	1639	9	3372	213T	T,C,X
182	I	1.2	2495	699	10	3252	213T	T,C,X
176	II	1.4	2581	1969	10	3362	213T	T,C,X
175	III	2.4	2588	1984	10	3372	213T	T,C,X
161	I	1.1	2820	697	11.2	3252	213T	T,C,X
159	I	1.3	2877	2016	11.2	3362	213T	T,C,X
159	II,III	2.2	2859	2031	11.2	3372	213T	T,C,X
145	I	1.0	3122	692	12.5	3252	213T	T,C,X
141	I	1.1	3228	2066	12.5	3362	213T	T,C,X
138	II,III	2.1	3280	2095	12.5	3372	213T	T,C,X
125	I	1.0	3654	2117	14	3362	213T	T,C,X
125	II,III	1.9	3626	2140	14	3372	213T	T,C,X
109	I,II	1.7	4163	2200	16	3372	213T	T,C,X
97	I,II	1.5	4688	2230	18	3372	213T	T,C,X
89	I,II	1.4	5092	2164	20	3372	213T	T,C,X
80	I	1.3	5675	2059	22.4	3372	213T	T,C,X
71	I	1.1	6369	1919	25	3372	213T	T,C,X
63	I	1.0	7209	1733	28	3372	213T	T,C,X

- \diamond **Standard Motor Types** (see page 13 for product codes)
 - T TEFC, three phase, 208-230/460 or 575 volts
 - C Corro-duty, three phase, 230/460 or 575V
 - X Explosion proof, CI 1 Grp D, CI 2 grps F&G, three phase, 230/460 or 575V



GEARMOTORS

CbN3000 SERIES

10 HP

General Specifications: Totally enclosed, 60 hertz, 40°C ambient, continuous duty.

Output RPM	AGMA Class	Service Factor	Output Torque in-lb	OHL lb	Nominal Ratio	Frame Size Gear	Frame Size Motor	Std. Motor Types ◊
1423	I	1.2	434	230	1.25	3201	215T	T,C,X
1389	I,II	1.4	446	616	1.25	3301	215T	T,C,X
1207	I	1.1	512	222	1.4	3201	215T	T,C,X
1199	II	1.4	514	629	1.4	3301	215T	T,C,X
1129	I	1.1	546	216	1.6	3201	215T	T,C,X
1087	I	1.3	567	637	1.6	3301	215T	T,C,X
1000	I	1.1	618	200	1.8	3201	215T	T,C,X
989	I,II	1.4	626	643	1.8	3301	215T	T,C,X
902	I	1.0	684	183	2	3201	215T	T,C,X
836	I,II	1.4	718	648	2	3301	215T	T,C,X
778	I,II	1.4	794	648	2.24	3301	215T	T,C,X
678	I,II	1.4	912	645	2.5	3301	215T	T,C,X
601	I	1.2	1027	637	2.8	3301	215T	T,C,X
554	I	1.0	1115	628	3.15	3301	215T	T,C,X
452	I,II	1.6	1353	556	4	3242	215T	T,C,X
442	III	2.6	1376	1516	4	3362	215T	T,C,X
383	I,II	1.4	1531	559	4.5	3242	215T	T,C,X
381	III	2.3	1587	1572	4.5	3362	215T	T,C,X
359	I	1.3	1727	559	5	3242	215T	T,C,X
346	II,III	2.1	1749	1610	5	3362	215T	T,C,X
318	I	1.2	1954	557	5.6	3242	215T	T,C,X
313	II	1.9	1932	1649	5.6	3362	215T	T,C,X
287	I	1.0	2220	551	6.3	3242	215T	T,C,X
273	II	1.6	2217	1702	6.3	3362	215T	T,C,X
247	I,II	1.5	2450	1740	7.1	3362	215T	T,C,X
229	I	1.0	2650	600	8	3252	215T	T,C,X
223	II,III	2.1	2714	1796	8	3372	215T	T,C,X
215	I	1.3	2813	1791	8	3362	215T	T,C,X
192	I	1.1	3168	1833	9	3362	215T	T,C,X
192	II,III	1.9	3131	1852	9	3272	215T	T,C,X
176	I	1.0	3441	1862	10	3362	215T	T,C,X
175	II	1.8	3451	1889	10	3372	215T	T,C,X
159	I,II	1.7	3812	1926	11.2	3372	215T	T,C,X
138	I,II	1.5	4374	1880	12.5	3372	215T	T,C,X
125	I,II	1.4	4834	1798	14	3372	215T	T,C,X
109	I	1.3	5550	1655	16	3372	215T	T,C,X
97	I	1.1	6250	1499	18	3372	215T	T,C,X
89	I	1.0	6789	1370	20	3372	215T	T,C,X

◊ **Standard Motor Types** (see page 13 for product codes)

T TEFC, three phase, 208-230/460 or 575 volts

C Corro-duty, three phase, 230/460 or 575V

X Explosion proof, CI 1 Grp D, CI 2 grps F&G, three phase, 230/460 or 575V



GEARMOTORS

CbN SERIES 3000

15 HP

General Specifications: Totally enclosed, 60 hertz, 40°C ambient, continuous duty.

Output RPM	AGMA Class	Service Factor	Output Torque in-lb	OHL lb	Nominal Ratio	Frame Size Gear	Motor	Std. Motor Types ◊
442	I,II	1.7	2064	1430	4	3362	254T	T,C,X
381	I,II	1.5	2380	1473	4.5	3362	254T	T,C,X
346	I,II	1.4	2624	1501	5	3362	254T	T,C,X
313	I	1.2	2898	1512	5.6	3262	254T	T,C,X
273	I	1.1	3326	1426	6.3	3362	254T	T,C,X
223	I,II	1.4	4071	1445	8	3372	254T	T,C,X
193	I	1.3	4696	1316	9	3372	254T	T,C,X
175	I	1.2	5176	1207	10	3372	254T	T,C,X
159	I	1.1	5718	1076	11.2	3372	254T	T,C,X
138	I	1.0	6561	858	12.5	3372	254T	T,C,X

◊ **Standard Motor Types** (see page 13 for product codes)

T TEFC, three phase, 208-230/460 or 575 volts

C Corro-duty, three phase, 230/460 or 575V

X Explosion proof, CI 1 Grp D, CI 2 grps F&G, three phase, 230/460 or 575V